

free flight • vol libre

3/90
Jun-Jul

\$3.50



POTPOURRI

Our Past President, Gordon Bruce, told me that writing the President's message "Potpourri" was hard to get started; this is only my second one and I agree!

Now that I've got the start over with, I can proceed.

The office is receiving more Pioneer Trust Fund donations and Life Memberships, these are always welcome. We hope that one day the Pioneer Trust Fund will be large enough that it will generate an income equal to what we received from the federal government in the past. Remember that SAC can use only half of the interest the fund generates for general revenue and returns, the other half to the fund. In this way it will continue to grow to guarantee a firm financial future for SAC.

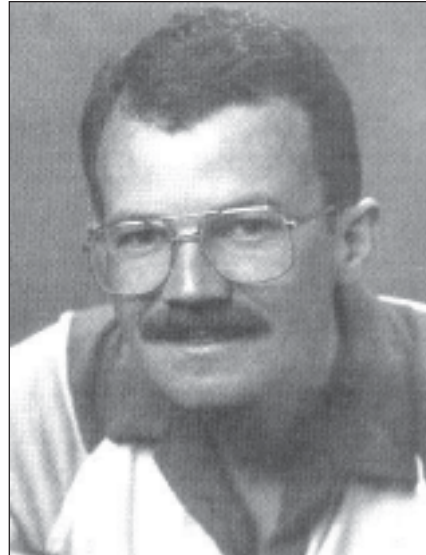

SAC has a bright future, but it also has a colourful past. In five years it will be our 50th anniversary! Now is the time for us to make plans. If you have any suggestions how we can mark the occasion, write to me. If you have any stories about the early years, put pen to paper, before you forget!

Gordon Bruce and I have met at the office twice now and among other things have been reviewing the SAC Procedures Manual, which is our guide for the operation of the Association. It is well written but needs to be updated. Most of you will be surprised to learn that every club was given at least one copy — where is your club's copy? Once we are finished with the revisions, a new one will be sent to every club.

At the office in Ottawa, Nancy has received most of the club's submissions for memberships and insurance. As you can imagine they come almost all at once, and for those who sent in clear and correct information, we thank you. Some aren't so clear and Nancy has to contact the club to figure out what money is for insurance and what is for membership.

In the past few months that I've been your President, I've been very busy, often spending the whole evening writing letters or making phone calls. It has been very enjoyable with very few sour grapes in the bunch. We are all volunteers — whether we're a wingtip runner, instructor, towpilot, grass cutter, committee member or association president. We're all doing it to make soaring safe and enjoyable.

Hope you have a great soaring season!

Chris Eaves

free flight • vol libre

Trademark pending Marque de commerce en instance

3/90 Jun – Jul

The journal of the Soaring Association of Canada
Le journal de l'Association Canadienne de Vol à Voile

ISSN 0827 – 2557

- 4 **Desiderata**
Anon.
- 6 **All about thermals**
Complete details on thermal structure — Tom Bradbury
- 12 **Growing up in Pendleton**
Childhood memories to solo at GGC — Graham Payne
- 14 **Aerotow training**
Making it easier for the student — Larry Morrow
- 15 **FAI Gliding Committee report**
Notes on the March meeting — Colin Bantin
- 16 **“Puchatek”**
A new two-seater from PZL — Josef Repsch
- 21 **SAC trophies**
Honours and awards and how to fly for them — Harold Eley

DEPARTMENTS

- 5 **Opinions** — insurance admin fee misuse? trophies, travel, trust funds
- 17 **SAC Affairs** — insurance, BC report, Ontario report
- 18 **Hangar Flying** — 1-26 Association records set, ground effect, the longest and biggest Murphy
- 16 **Club news** — the best ever open house, new Red deer club, where's all the club news?
- 19 **CASG news** — a cure for March (spring gliding workshops)
- 21 **FAI page** — current badges

Cover

The Vancouver Soaring Association's Twin Grob at the rear and the “Baby Grob” are ready to go at the Hope airfield.

photo by George Eckschmiedt

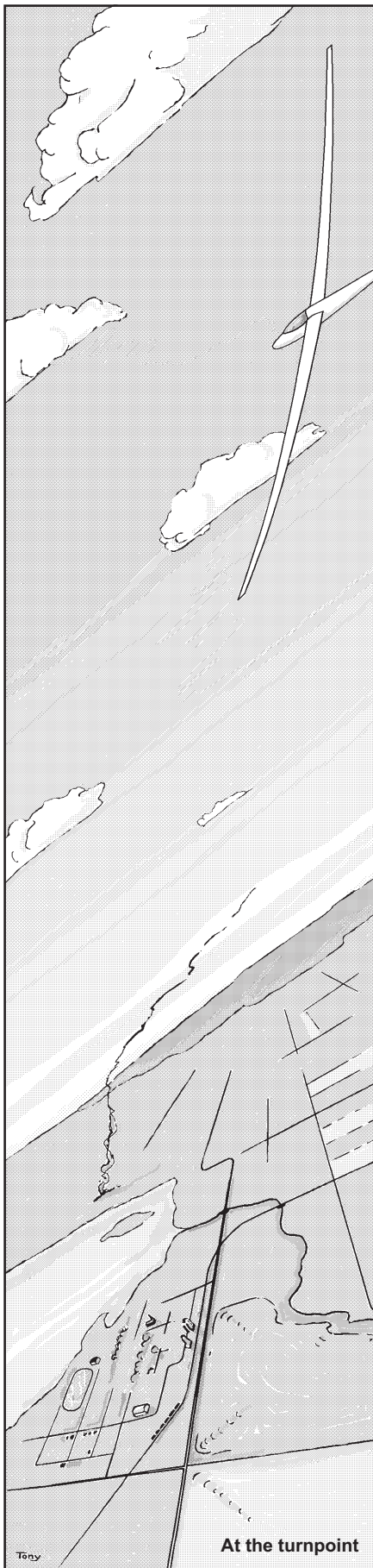

DESIDERATA

Go placidly amid the noise of the towplanes & remember what peace there is in the silence at 5000 feet • As far as possible without surrender, be on good terms with the towpilot • Speak your truth quietly & clearly; and listen to others, even the dull & ignorant — they too have their good flights • Avoid loud & aggressive persons, they are vexations when you are preparing to fly • If you compare yourself to others, you may become vain or bitter, for there always will be novices or diamond pilots about • Enjoy your achievements as well as your plans; keep trying for that next badge leg • Exercise caution in competition for contest pilots are full of guile • But let this not blind you to what virtue there is; many pilots striving for height get help from those already in lift • Be yourself • Especially do not feign affectation • Neither be cynical about lift, for in the face of sink and poor landing areas, it is as perennial as the grass • Take kindly the counsel of the years — gracefully surrendering the things of youth • Let the younger club members push the gliders to the flight line • Nurture strength of spirit to shield you when lift fails • But do not distress yourself over poor forecasts, many fears are born of fatigue & loneliness in the cockpit • Beyond a wholesome discipline, be gentle with the controls • You are a child of the universe, no less than the power pilots & jet jockies; you have a right to some airspace • And whether or not it is clear to you, no doubt the universe is unfolding as it should • Therefore be at peace with the CFI, whatever you conceive him to be; and whatever your labours & aspirations this season, in the noise and confusion on the flight line, keep peace with your fellow pilots • With all its sham, drudgery & broken dreams, it is still a beautiful sport • Be careful • Soar to be happy •

Found in the map pocket of an old 2–22, dated 1954.



The SOARING ASSOCIATION OF CANADA

is a non-profit organization of enthusiasts who seek to foster and promote all phases of gliding and soaring on a national and international basis. The association is a member of the Aero Club of Canada (ACC), the Canadian national aero club which represents Canada in the Fédération Aéronautique Internationale (FAI), the world sport aviation governing body composed of national aero clubs. The ACC delegates to SAC the supervision of FAI related soaring activities such as competition sanctions, issuing FAI badges, record attempts, and the selection of a Canadian team for the biennial World soaring championships.

free flight is the official journal of SAC.

Material published in **free flight** is contributed by individuals or clubs for the enjoyment of Canadian soaring enthusiasts. The accuracy of the material is the responsibility of the contributor. No payment is offered for submitted material. All individuals and clubs are invited to contribute articles, reports, club activities, and photos of soaring interest. Prints (B&W) are preferred, colour prints are acceptable. Negatives can be used if accompanied by a print.

free flight also serves as a forum for opinion on soaring matters and will publish letters to the editor as space permits. Publication of ideas and opinion in **free flight** does not imply endorsement by SAC. Correspondents who wish formal action on their concerns should contact their SAC Zone Director whose name and address is given in the magazine.

All material is subject to editing to the space requirements and the quality standards of the magazine.

The contents of **free flight** may be reprinted; however, SAC requests that both **free flight** and the author be given acknowledgement.

For change of address and subscriptions to non-SAC members (\$20 per year, US\$22 in USA, and US\$28 overseas), please contact the National Office, address below.

President Chris Eaves
Vice President Harald Tilgner
Executive Secretary Nancy Nault
Corporate Treasurer Gordon Bruce
Corporate Secretary Nancy Nault

SAC National Office
Suite 306, 1355 Bank Street
Ottawa, ON K1H 8K7
(613) 739-1063
Fax (613) 739-1826

5

Deadline for contributions
5th day of each ODD month

Opinions

L'ASSOCIATION CANADIENNE DE VOL À VOILE

est une organisation à but non lucratif formée de personnes enthousiastes cherchant à développer et à promouvoir le vol à voile sous toutes ses formes sur une base nationale et internationale.

L'association est membre de l'Aéro Club du Canada (ACC) représentant le Canada au sein de la Fédération Aéronautique Internationale (FAI), administration formée des aéro clubs nationaux responsables des sports aériens à l'échelle mondiale. Selon les normes de la FAI, l'ACC a délégué à l'Association Canadienne de Vol à Voile la supervision des activités de vol à voile telles que tentatives de records, sanctions des compétitions, délivrance des brevets de la FAI etc. ainsi que la sélection d'une équipe nationale pour les championnats mondiaux biennaux de vol à voile.

vol libre est le journal officiel de l'ACVV.

Les articles publiés dans **vol libre** sont des contributions dues à la gracieuseté d'individus ou de groupes enthousiastes du vol à voile.

Chacun est invité à participer à la réalisation de la revue, soit par reportages, échanges d'opinions, activités dans le club, etc. Un "courrier des lecteurs" sera publié selon l'espace disponible. Les épreuves de photos en noir et blanc sont préférables à celles en couleur. Les négatifs sont utilisables si accompagnés d'épreuves.

L'exactitude des articles publiés est la responsabilité des auteurs et ne saurait en aucun cas engager celle de la revue **vol libre**, ni celle de l'ACVV ni refléter leurs idées. Toute correspondance faisant l'objet d'un sujet personnel devra être adressé au directeur régional de l'ACVV dont le nom apparaît dans la revue.

Les textes et les photos seront soumis à la rédaction et, dépendant de leur intérêt, seront insérés dans la revue.

Les articles de **vol libre** peuvent être reproduits librement, mais la mention du nom de la revue et de l'auteur serait grandement appréciée.

Pour changements d'adresse et abonnements aux non membres de l'ACVV (\$20 par an, EU\$22 dans les Etats Unis et EU\$28 outre-mer) veuillez contacter le bureau national.

EDITOR

Tony Burton (403) 625-4563
Box 1916
Claresholm, Alberta T0L 0T0

Any service by Canada Post to above address. Commercial courier service, c/o "Claresholm Local Press"

COMMERCIAL ADVERTISING
National Office (613) 739-1063

Date limite
le 5 de chaque mois IMPAIR

5

INSURANCE ADMIN FEE MISUSE?

I'm writing this not in my capacity of a member of the SAC Insurance committee, but simply as a SAC member who is fairly well versed in the subject. From its inception the SAC insurance plan was organized as a self-help project to defend member clubs against the vagaries of dealing with insurance companies who had no idea of the risks involved in soaring. It was a form of circling the wagons in a common defence against impossibly high rates and poor policy conditions. Private owners were included because of common interest, and to increase the size of the insured pool. One of the original objectives was to make sure that the insurance plan had to stand on its own feet financially, would receive no subsidies from the SAC general membership and would have to reimburse SAC for the administrative costs incurred. The benefit to SAC would be derived from the fact that SAC member clubs and SAC member private owners could obtain insurance rates and policy conditions not otherwise available, and therefore would make SAC membership more attractive. Over the years the SAC insurance plan has met these objectives in an admirable manner.

Lately another objective seems to have quietly crept into the plan, namely to provide cash for SAC's general revenue account as a substitute to raising normal SAC member dues. I have always objected to this on the grounds that it can become a means for the directors to keep dues artificially low and to hide the true cash requirements from the general membership. This conflicts with the original objective to keep the insurance plan apart from and independent of SAC's general revenues and expenses.

Now consider the recent past. A policy fee of \$25 per insured aircraft was introduced some years ago as a means to reimburse SAC for the time SAC staff spent on insurance matters, ie. premium collection, mailing insurance announcements, etc. At 300 insured aircraft this produces \$7500 for SAC. If one is very generous in time allocation, SAC staff spends 100 hours on this task per year. At a pay rate of \$15 per hour the cost to SAC is \$1500. Add to this a generous \$500 for mailing and phone costs, and the total cost to SAC of administering the insurance plan is \$2000. On the plus side, SAC not only receives a \$7500 fee, but also gets to keep the interest earnings on the "float", the amount of money in SAC's possession between the time premiums are received and passed on to the insurers. If we figure a minimum of one-half the premiums for 30 days ($320,000 \times 1/2 \times 10\% / 12$) this produces another \$1250 per year, for a total of \$8750. Not a bad return on a \$2000 investment. In fact the numbers can be somewhat higher, because more than 300 aircraft are insured, and the float is calculated very conservatively.

In spite of this, and over the strong objections of the Insurance committee, the SAC directors decided to increase the policy fee to \$30 a year ago. The actual earnings to SAC from the insurance plan must have exceeded \$10,000. For this year the Insurance committee in the strongest terms recommended a return to the \$25 policy fee, but were overruled again. This in spite of the fact that due to some vagaries of the premium accounting the plan produced a windfall profit of an additional \$8000. In my opinion this amount should be prorated among the insured aircraft and returned to the clubs and owners. There seems little point in the Insurance committee fighting tooth and nail for minimum premiums when the SAC board sees any such savings as an additional means to increase SAC general revenues. If SAC general operations need additional funds, let the general membership review the SAC budget and decide if the additional need is worth higher dues.

At the very least SAC owes the insured clubs and private owners an exact accounting of the real costs and revenues involved in the insurance administration. Let the insured decide if they want to make a special contribution to SAC general revenues.

A.O. Schreiter

Response by Chris Eaves, SAC president

Mr. Schreiter's letter makes it clear that he doesn't appreciate how much time the SAC office spends administering the insurance scheme. Exactly how much is debatable, but Nancy's best guess is 360 hours per year, not 100 as Mr. Schreiter suggests. If we sent perfect information to the clubs and they sent perfect information back, 100 hours would be reasonable, but that has not happened yet. Every phone call and letter to correct an error costs us money. The so-called windfall profit of \$8000 Mr. Schreiter refers to is a discrepancy between what we know we still owe the insurance company from last year and what they think we owe. It isn't ours yet and it would be premature to think of it as profit.

A detailed accounting of expenses for administering the insurance is impossible now because the office hasn't kept track of either the time it spends on insurance matters or the other related expenses. We will from now on, and if we are unable to justify the administration fee of \$30, it will be lowered in the future.

The SAC insurance scheme is one of many things that we do well, and it benefits all of our members. When we get a request from a new club wanting to join SAC, their letter always includes a request to be included in our insurance scheme.

continued on page 20

ALL ABOUT THERMALS

THERMALS are probably as individual as fingerprints, many share common features but no two are identical. Their scale ranges from columns 50 feet in diameter, usable only by seagulls and buzzards, to mile wide monsters sucking thousands of tons of air a second into giant cu-nim clouds.

Tom Bradbury

from SAILPLANE & GLIDING

Laboratory studies of thermals

Until a cloud forms there is almost nothing to show the shape or size of a thermal. Atmospheric thermals are too big to be studied in a laboratory but one can produce similar motions in a water tank using fluids of different density. Many experiments were done by releasing salt water (made visible by a white precipitate) into a tank of clear water. A series of photographs was taken as the denser saline cloud sank through the clear water. These pictures, when inverted, looked remarkably similar to a real cumulus cloud. The experiments led to the now familiar picture of a thermal bubble rather like a vortex ring but not exactly similar.

Figure 1(a) shows successive two dimensional outlines of a water tank "thermal". The arrows show how protuberances which began near the centre line fanned out sideways. In 3D this showed that the circulation was formed by fluid rising up the middle of the thermal, spreading out in all directions at the top, and then sinking down the outside. The vertical motion in the core of the bubble was about twice that of the cap.

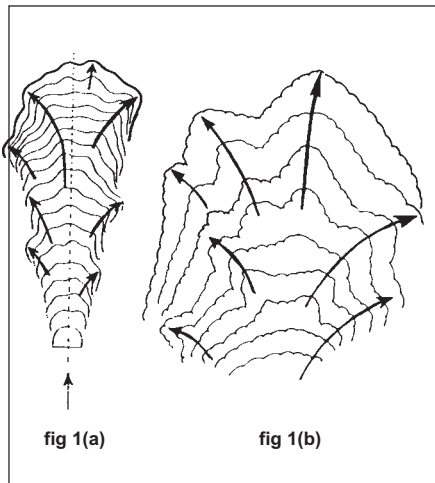
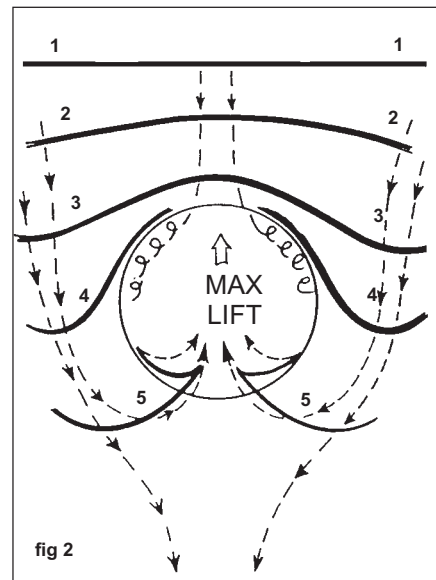

Figure 1(b) shows outlines of a developing cumulus with individual turrets being displaced sideways as new turrets rise up from within the body of the cloud to take over. Real clouds have also been found to have their strongest upcurrents rising about twice the speed of the cloud top.

The vortex ring

Some laboratory models show that the artificial "thermal" forms a vortex ring circulation before it dies out. Part of the surrounding air is pulled into the circulation of this expanding ring, diluting the thermal. Eventually the weakening thermal loses the rest of its energy trying to accelerate this additional air. The ring ceases to rise and soon decays.



Flow into a thermal bubble

Figure 2 above shows a highly simplified diagram of how a rising thermal bubble can incorporate outside air into its circulation. The circle in the centre represents the bubble. Dashed lines show how air from above flows round the thermal. The numbered black lines above and round the side show how an origi-

nally flat layer of air is distorted as the bubble comes up through it: (1) shows the undisturbed line, (2) and (3) show the upward push developing as the bubble approaches. Notice that a small upward push occurs before the bubble actually arrives. If the air is already very moist this may be enough to form a thin lenticular cap called "pileus". At (4) the line is broken by the bubble. Some of the air is mixed into the rising cap while the rest slides round the edge. As it nears the bottom of the thermal bubble (5) the line is distorted by the curving inflow. This inflow takes drier air back up into the bubble. In some cases the arrival of drier air turns the bubble into a sort of doughnut ring with a clear hole in the centre (when viewed from above). The flow in and around a real cloud is not as simple as this. The complete vortex ring pattern seldom appears unless the thermal is forced to rise fast; for example due to some massive burst of heat such as an atomic bomb.

Nuclear explosions and thermals

The most dramatic example of a thermal bubble is formed by a nuclear explosion. Photographs taken after the initial fireball has cooled show a long column extending up from the ground capped by the well-known mushroom cloud surging upwards. Figure 3 is a sketch of two stages in the life of an atomic cloud. On the left the original fireball is still too hot for any moisture to form a cloud. The bubble has a tail of debris swept up from the ground. In the right hand sketch

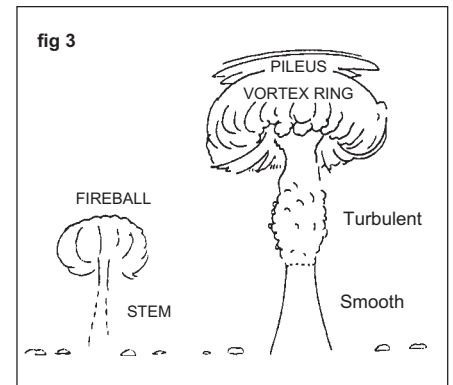

the expanding mushroom has expanded and cooled enough for moisture to condense forming a white cloud. The underside of the mushroom shows how the outside air is being drawn up into the core from below, just like the model thermal. The column below consists of extra moisture sucked up from lower levels and condensed into cloud as it cooled.

Pileus

The speed of ascent has also produced a smooth lenticular cap (called pileus) formed from outside air pushed up ahead of the mushroom cloud. Pileus sometimes appears above ordinary cumulus if the air aloft is very moist. The pre-thermal lift causing it appears in figure 2 as a bend in lines 2 and 3.

Double bubbles

In another water tank experiment a second "thermal" bubble was released after the first had risen some distance. This is illustrated in figure 4. AA is the first thermal. BB is the follower. Timing of BB could be critical. If released at the right time, BB would rise through the centre of the expanding vortex ring formed by AA and accelerate upwards. However, if the delay was too long, BB tended to break up in the turbulent wake of AA and never got through the sink.

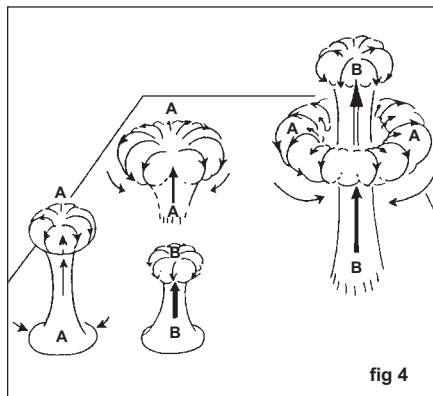

The theory of a thermal bubble seems to be supported by the experience of pilots circling in the central core of a thermal who find it possible to close the gap between them and gliders higher up. Those at the upper level only go up at the speed of the bubble but in the core lower down the air rises twice as fast. Eventually everyone is left circling round at the top of the bubble in weak lift. Occasionally a newcomer picks up a fresh bubble lower down and catches up to the gaggle. If this sailplane is in a BB type thermal, everyone else will start to climb faster when the new bubble arrives; if not all will stop climbing at about the same height.

The idea of consecutive bubbles can be comforting to a pilot searching round at low level in the decaying dregs of an old thermal. Quite often patience is rewarded and a new and vigorous bubble comes pushing up. However the following bubble does not necessarily rise directly beneath the original one. One may have to shift the search upwind.

Thermals and cloud forms

Once cloud has formed, the latent heat of condensation releases an extra supply of heat which invigorates the thermal. The shape of a cloud provides an excellent marker showing how much air has been affected by the thermal. The rising cloud dome is covered with lots of smaller protuberances like tiny thermals. These mark the region where drier outside air is being mixed into the thermal and diluting it.

Time lapse films suggest that, although most clouds show similarities to the laboratory models, the larger clouds are usually complicated by the existence of several originally separate thermals. The cloud shape is distorted by collisions with inversions and twisted by the effect of vertical wind shear. Since most clouds persist longer than thermals, their shape reveals more about the past history of the thermal than its present condition. Lift under a cumulus is usually confined to a relatively small area where an active plume enters. The rest of the cloud just marks where ascent took place some time ago.

Plumes and bubbles

Figure 5 shows what probably occurs in the atmosphere starting with a large but relatively shallow reservoir of warm air. Level 1

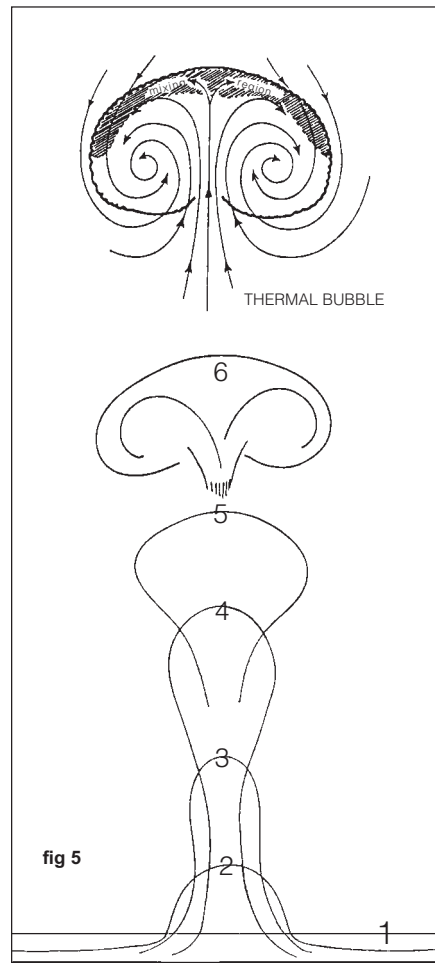

is the initial state; levels 2, 3, 4 and 5 are stages in the ascent of a column of warm air. Such a rising column has been termed a "plume". It represents the stage before the

circulation at the top develops into a detached thermal bubble. Notice that as the plume accelerates upward (levels 3 and 4) the diameter of the column narrows for a time before widening out and then developing a mushroom like shape at the top. This narrowing is why one often has to turn much tighter to climb away in thermals low down. Higher up the mass of air comprising the thermal grows wider but the lift is confined to the central core. The airflow at the top of the thermal is continually spreading outward but any vortex ring pattern is only partially developed in the early stages.

By the time the supply of warm air is exhausted, (level 6) the full circulation of the thermal bubble has developed. This is shown in more detail at the top. The shaded area is where most of the mixing takes place. The circulation carries the diluted mixture down the sides of the bubble and eventually some is drawn into the base. The mixing process is called "entrainment". This reduces buoyancy by diluting the thermal and also absorbs some of the spin as slow moving air from outside is pulled into the vortex ring. As a result the initial bubble often slows down and disperses well below the level it could reach if undiluted.

There is sometimes an argument between people who feel that a thermal is better represented by a tall plume of rising air rather than a bubble. It seems likely that both forms occur, with the bubble being the most likely shape after the supply of warm air from the surface has been cut off.

Any ring circulation usually disappears when the cloud top ceases to rise. In many cumuli this circulation seems to be so slow that it never becomes a complete ring. Distortions due to encounters with wind shear and inversions usually prevent a symmetrical ring forming. The tops of many dying cumuli look inert. Not only does any ring circulation vanish but the cloud top may fall back into the main body of the cloud as an evaporation down-draft develops. Figure 6 illustrates the destruction of a central column of cloud in this manner. Such a downdraft tends to reverse the original circulation at the cloud top.

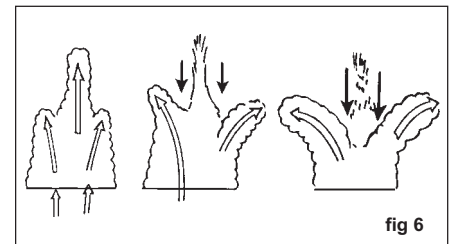

Evaporation downdrafts and holes in the clouds

Water tank models are unable to reveal the effect of evaporation in a cumulus cloud. Evaporation occurs when the growing cloud incorporates much drier air from above. When the dry air enters it forms pockets of evaporation which eventually make holes in the cloud. The heat needed for evaporation cools the air so much that regions of sink develop. Researchers have found these holes on a wide range of sizes between 10 and 100 metres growing to 500 metres. Larger holes

occur in multi-cell groups of cloud. Generally there are more small holes than large holes. They produce sink going down into the middle of the cloud (not just at the edges as the basic model suggests). This central sink tends to disrupt any strong core of lift in the middle of the thermal bubble. Soon the circulation no longer resembles the basic model. If you watch the cloud shadow you may see the solid black area break up into a ragged "fishnet" pattern as evaporation erodes the cloud and the sink takes over.

Sloping thermals

Unless the air is practically calm for several thousand feet, thermals are likely to be tilted over by the wind. However, the amount of tilt depends to a great extent on the strength of the thermal. A soarable thermal contains thousands of tons of air and this mass has considerable inertia. If this mass starts off with a low ground speed it tends to maintain its original speed, even when it rises into a stronger wind. The upper winds are then diverted round the side or deflected over the top of the thermal. This is why some cumulus can produce lift in the clear air on the windward side and transient waves over the top of the cloud.

The influence of wind shear is sometimes visible in the shape of clouds. While they are growing strongly they usually remain fairly vertical. When the thermal dies the stronger winds aloft tend to topple the cloud over. It then starts to evaporate in the strong sink on the downwind side. This alters the look of the cloud. The growing side keeps producing clear cut bulges while the sinking side develops a fuzzy outline as evaporation starts to shred the cloud.

Effects of wind shear above shallow cumuli – hook shapes

The distortion produced by wind shear depends on the rate of ascent of the cloud and the amount of shear. On most good soaring days the tops of cumuli are limited by a layer of stable air higher up. If there is a well marked inversion, there may also be a noticeable wind shear above it. The cloud top quickly stops rising when it reaches the inversion and any part which overshoots tends to be twisted over into a hook like shape as shown in figure 7. One may see several little hook shapes appearing briefly on the up-shear side of these clouds. When the end of the hook starts to turn down, it begins to evaporate so one cannot see the full effect of the sink which develops on the down-shear side. Sometimes almost all the cloud evaporates leaving just a puzzling narrow hook shape.

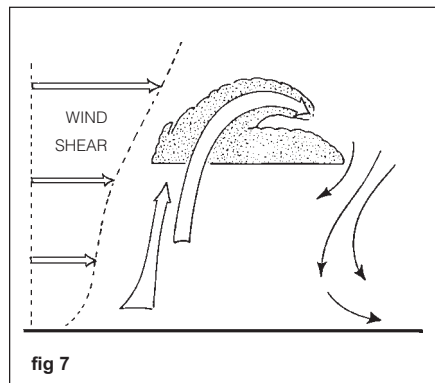

fig 7

Wind shear with deeper instability

There are occasions when, although the air is unstable to 10,000 feet or more, the surface heating is only just enough to set off thermals. With only a small excess of heat these thermals rise slowly at first. When they reach the condensation level so much extra energy is released that the cloud starts to shoot up rapidly producing long thin columns. Cumulus clouds formed over tropical oceans sometimes behave like this. There is very little lift underneath these oceanic clouds except close to cloud-base. Once into cloud the lift often becomes strong. The clouds remain narrow if the surrounding air is fairly dry. However, tall thin cumuli usually have a short life and such clouds are soon tilted over by stronger winds aloft. Figure 8 is a sketch of a series of thermals which produced similar tall cu over the Cotswolds on 24 September. On this day the wind was almost calm at low level. Clouds were chiefly confined to high ground with large blue areas over the Severn valley. The numbers in figure 8 show a succession of plumes breaking off into individual bubbles. Number 1 furthest downwind is in the decaying stage; 2 and 3 show how the tilt increased with time. The originally firm cloudbase degenerated into a ragged skirt marking sink under 3 and beginning under 4. Cloud 5 was still growing well but the lift beneath was shut off. Only cloud 6 was accessible from below.

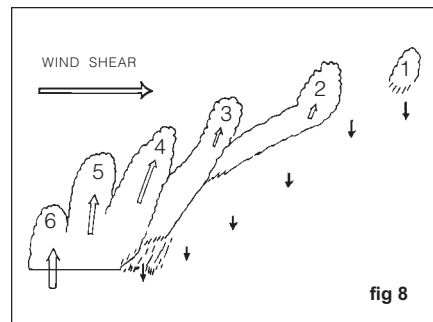

fig 8

Stubble fires and thermals

It can be instructive to watch the behaviour of smoke from a stubble fire. Of course the extra heat put out by these fires varies enormously. Much depends on how the fire was lit and whether the flames have to work their way feebly upwind through a sparse cover of stubble or are allowed to sweep downwind through piles of deep straw. It is worth noting that unless the air has neutral stability (a dry adiabatic lapse rate) even the fiercest stubble fire is unlikely to send up a soarable thermal. I have watched a stubble fire lit long after sunset which produced six foot flames but the smoke trail only made a feeble hump in the nocturnal inversion. The fact that most stubble fires do seem to initiate a thermal is because farmers usually wait till the overnight dew has evaporated and the straw is really dry before lighting up. The majority are set off fairly late in the morning and through the afternoon. The air is usually unstable by then.

Feeble fires

With the weaker type of fire, the smoke plumes frequently seem to

rise in a series of pulses rather than one solid column. This is particularly noticeable with long lasting fires when there is a fresh breeze blowing. After one upward surge has risen the smoke starts to trail along the ground almost horizontally until another surge is set off. This looks as if a series of thermals is moving across the stubble fire and the arrival of each thermal is marked by a fresh hump of smoke. Figure 9 illustrates the idea. Flying upwind towards the source of the

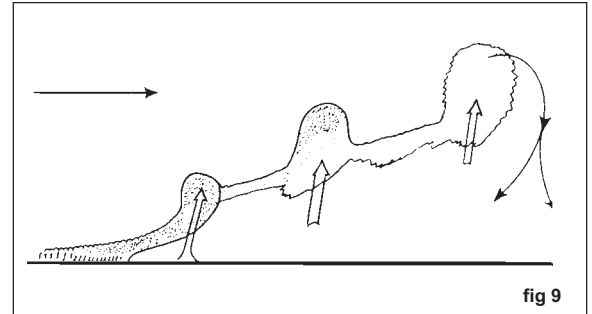

fig 9

smoke one can find the thermals well below the puffs of smoke. This suggests that the lift is not entirely due to the hot air from the fire. Feeble fires like this do not seem to produce mushroom clouds.

Fierce fires

Farmers seem to be more cautious nowadays and one seldom sees the really monster stubble fires with a vertical column of black or grey smoke towering up into a mushroom cloud. Some have minor whirlwinds spinning round at the base. Inside the plume the lift is astonishing but the air is so rough that one has very little control of the aircraft. Large clumps of burning straw appear and go rushing by. Occasionally they become doubled over the leading edge of the wing and are reluctant to slide off. I have side-slipped a thousand feet to get rid of such unwelcome hitch-hikers.

The fiercer the fire, the shorter its life

Astronomers tell us that many of the biggest and brightest stars use up their store of hydrogen quicker than their smaller brethren. After a brief surge of brilliance as a "super-nova" they subside into a much dimmer object. This is sometimes true of stubble fires too, especially those one sees many miles away. I have watched pilots fly past a 5 knot thermal under a nearby cumulus in their urge to sample a distant stubble fire. Sometimes they come back, very much lower down, to the cloud they had spurned fifteen minutes earlier; as moths make for a candle flame so pilots divert to stubble fires. I have diverted to a fire whose flames were high enough to be clearly visible more than ten miles away. When I arrived all that was left was a charred field and an inert pall of smoke much higher up.

More complex patterns

Only the smallest short-lived clouds are the result of a single thermal. Most are the work of a series of thermals. The individual turrets of large cumulus clouds show that there must have been several closely spaced thermals. Cloud streets show that thermals may be organized in a regular fashion which has lit-

tle to do with hot spots on the surface. There are other influences too such as the interaction between downdrafts or the result of outflows.

Multiple thermals

Thermals are not necessarily isolated columns of lift. Several can exist close together

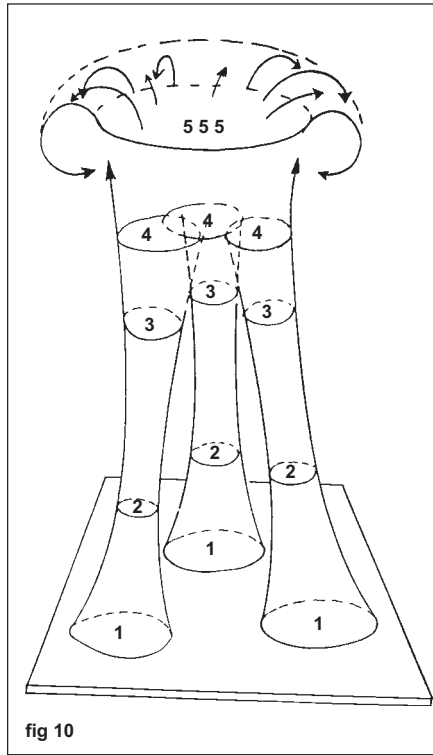

fig 10

as shown in figure 10. Such a group may be unsuspected when flying alone. One usually discovers these near a busy gliding site where a number of pilots are marking lift in different places. Quite often rates of climb seem to be similar in each column. At level 2 the circles are far enough apart to allow each group to climb safely. By level 3 turns are becoming uncomfortably close and at level 4 the overlap means someone must shift circles. At level 5 the columns have merged to form one of those comfortably wide thermals which occur well after midday and especially late in a summer afternoon.

Figure 11 shows a plan view of the lift distribution between levels 3 and 4. Beside it is a

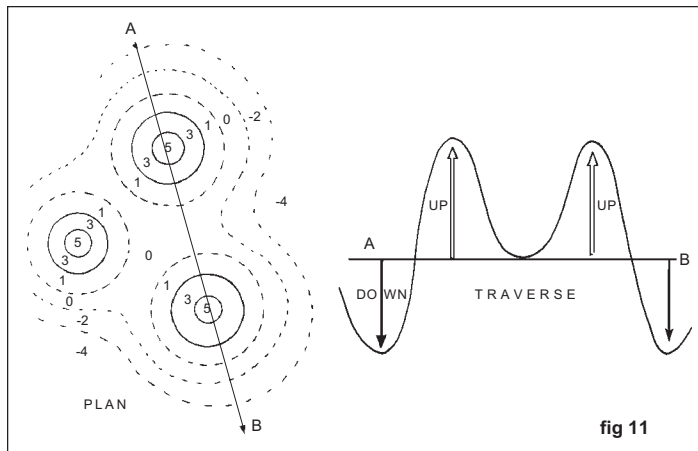

fig 11

cross-section of the lift encountered by an aircraft hurrying straight through along a line A-B. Some clusters of thermals have far more cores with less sink in between. When lift is distributed like this it is difficult to know whether one should tighten up the turn in a surge of lift or take off bank. If you are the only one in such a thermal and in no hurry to press on, the pattern of lift can be explored for quite a long time. However, it is hard to build up a mental picture of it. The only certainty is that a cross-section of lift is not circular.

Street of lift – horizontal vortices

The upper part of figure 12 shows a familiar pattern of clouds in long, regularly spaced streets which are aligned parallel to the wind at their altitude. Such streets occur when the tops of cumuli are restricted by an inversion so that they all reach approximately the same level. If there is also a moderate to strong wind, a convective circulation develops in the form of long lines of parallel contrarotating vortices. These produce lines of lift under the clouds with lines of sink in the clear air in between. By tracking constant pressure balloons, researchers have found that the air is following a helical path. The cross-section in the lower half of the diagram illustrates a two dimensional circulation.

Such streets do not depend on any hot spots on the surface; they form spectacularly well over the ocean where strong winds bring cold air spreading out from polar regions. The circulation of these cloud street vortex rolls extends from the surface up to the base of the inversion. The spacing depends very largely on the depth of unstable air, the deeper the layer the wider the gap between streets. If the depth of unstable air increases, the widening of the cloud free lines is achieved by destruction of some of the intermediate streets, not by a fanning out of all streets. Streeting breaks down when the air becomes too unstable, and tops are no longer at a uniform level.

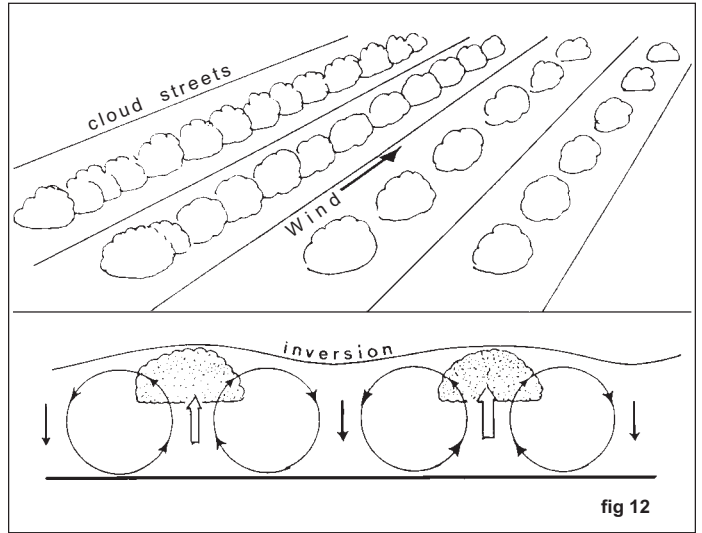

fig 12

Chimney vortices

Old fashioned steam locomotives sometimes emit a series of perfect smoke rings if the puffs leave the chimney with just the right force. These are true vortex rings initially but they usually break up after a short time. The gases from a factory chimney never come out with such vigour. They tend to dribble out in a sluggish series of puffs or, if there is a breeze over the top, form a small pair of contrarotating vortices. Looked at from downwind (see the left hand side of figure 13 on the next page) they appear like a two dimensional cross-section of an ideal thermal bubble. Instead of a complete ring rising almost vertically there are two horizontal rolls trailing downwind. These rolls have an updraft in the centre and downdraft at the outside. The rolls occasionally spread apart leaving a clear gap in between where clean air from outside has been pulled into the circulation. This is a two dimensional example of the kind of circulation which produces a doughnut shaped hole in a 3D thermal bubble.

Knife-edge “thermals”

On rare occasions one may encounter an extremely narrow line of lift which gives the impression one is flying along a knife-edge of rising air. I believe this is a much larger version of the chimney vortex pattern illustrated in figure 13. The suggested circulation has been drawn on the right hand side of the figure. Its size probably lies between a full sized street and the tiny chimney vortices. These vortex rolls produce a very

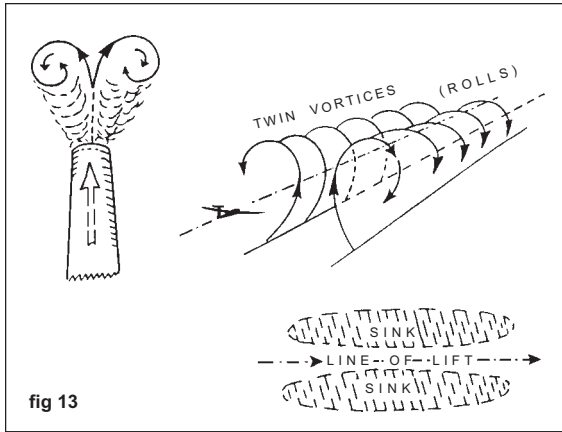

fig 13

narrow line of lift. One may encounter the effect after leaving a thermal. This lift is usually weak, often barely 1 knot, but it can extend for a mile or more. The line is much too narrow for circling, unlike a cloud street where one can stop and circle for extra height. Circling between these vortex rolls invariably takes one into sink whether the turn is to the left or right. Straighten up on to the original course after turning 360 degrees, and the lift returns.

Misleading indications

It is a common fault for pilots accustomed to the narrow thermals found over the British Isles to turn too soon on finding lift. This is more likely to happen when one has been flying fast between thermals and is now approaching a height where another climb is needed. First one runs through the strong sink so often found on the edge of a good thermal. Then the sink stops quite suddenly, so that it gives the impression one has run into a surge of lift. At the same time the vario gives a frantic burst of squeaks. A turn takes the pilot straight back into sink for a complete circle. Straightening up and continuing on the original course one eventually finds the real thermal is actually quite a long way further on.

Figure 14 is an attempt to show how this deception occurs. The airflow in and around a cumulus cloud is apt to be much more complicated than the model of a thermal bubble suggests. Some of the complexities were discovered by sending up a barrage balloon which supported a chain of anemometers attached to the cable at different levels. When all the readings were combined, streamlines of flow were drawn. These were not at all what one might expect. The flow went up, down and horizontally in a surprising manner.

The little glider on the left (which is not to scale) has a pair of dotted lines from the cockpit to represent the sector being scanned by the pilot. At this position the pilot has the impression of being just under the cloud although really he is still a little way outside. (Pilots seldom look vertically upwards unless they are in a gaggle.) When point "A" is reached, the glider flies through one of the side eddies and the cessation of sink is followed by a sudden increase in airspeed due to the horizontal gust. The total energy system interprets this as lift. Perhaps the sudden increase in 'g' enhances the effect.

Three factors: the belief you are already well under the cloud and have reached point "B", the seat of the pants feel of a surge of lift, and the burst of excitement from the vario, all combine to fool simple pilots into starting a turn. It catches me regularly, particularly after rounding a turning point and beginning an into wind leg. I used to keep quiet about such lapses but was cheered recently to hear that competent pilots have been fooled the same way. The problem does not arise when you still have lots of height; then you just pull up and climb straight ahead, increasing speed again if it turns out to be a false indication. It doesn't matter if there really was a little thermal there or not because it was not needed.

Influence of waves aloft

Whenever there is a stable layer above the level of any mountains and the wind speed increases with height (while remaining fairly constant in direction) there is a possibility of waves. In the early morning or late evening one may see some indications in the shape of clouds. Often the air aloft is too dry for any lenticulars and during the heat of a summer day the lower levels are too churned up by convection currents for waves to exist low down.

It is not unusual to complete a flight using thermals and be quite unaware of wave lift above. Far away from the hills any changes in the thermals may be put down to normal variations. As your flight comes nearer the hills it may become apparent that some thermals are remarkably strong, the sink in between has got worse and some of the gaps are much wider than before.

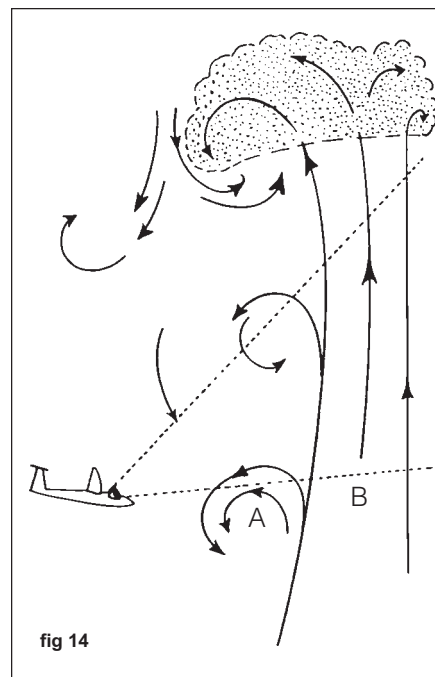

fig 14

This is particularly distressing when heading into wind, for example when flying from the east towards Wales. If nothing odd had been noticed earlier one's first suspicions are likely to be aroused on approaching the line from the Forest of Dean to the Malverns, Kidderminster and Bridgenorth. Further north it is the lee side of the Pennines where thermals are most likely to be affected by wave. Over Scotland one automatically looks for wave.

Waves aloft tend to boost the thermals which occur under wave lift and suppress those trying to rise into wave sink. Wave troughs coincide with blue holes. Figure 15 illustrates the sequence. Be warned that the gaps between the cumulus are normally larger than shown here. At first conditions seem to be improving as you fly from east to west (right to left on this diagram). Thermals become much stronger and some may be twice the average found further east. Then there is a gap where the post-thermal sink is unpleasantly strong and goes on far too long. Relief at reaching cumuli on the far side turns to frustration when it seems that none of them are working. Going downwind across such a

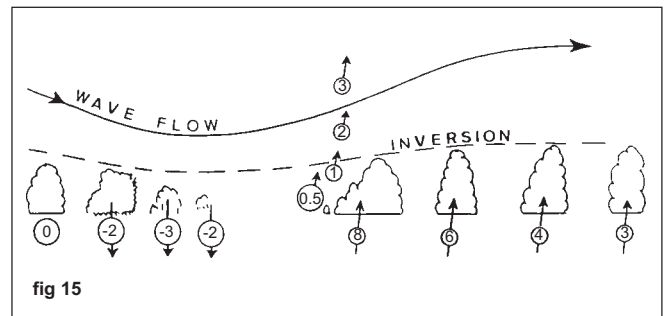

fig 15

gap is far easier. The tailwind reduces the time spent in the blue and the very first clouds on the far side work well.

It may be possible to get into the wave from the last strong thermal before the gap. It may not be necessary to make a cloud climb first though one should take the climb right up to cloudbase if possible. While climbing in the last thermal it may be necessary to straighten up each time the circle brings you into wind. This is because the normally circular pattern of the lift is distorted into an oval or race track shape by the wave. If one makes perfect circles the lift will apparently decrease as height is gained. By constantly shifting upwind one can keep in the best lift. (The same technique is useful when using thermals coming off a ridge.) In both cases a long lasting thermal "plume" is being triggered off from a particular place. If you are climbing in a single bubble where the central core is ascending more rapidly than the entire bubble the effect of the wind may not matter. In a plume whose base seems to be anchored to a ground feature one tends to be drifted out of the best lift.

One indication of wave is the continuation of lift (usually very weak) upwind of the last cloud. If the lift persists when you make a crosswind tack it probably is due to wave. Patient working of this lift, which is usually very feeble to start with, may eventually get you up to a level where there is a respectable rate of climb. If you are racing round a

triangle the time wasted becoming established in wave will seldom be regained, however if the blue gap upwind proves too wide, there may be no option but to turn tail and try for the wave.

Triggers for thermals

Cloud streets and upper waves are examples of methods of setting off a series of thermals. If one excludes the very first thermals of the day, it is likely that many new thermals are dislodged from the surface by the sink from air displaced by older thermals coming right down to the ground and then spreading out horizontally.

Over a flat ground a shallow layer of air can be warmed to a temperature well above what is theoretically necessary to set off a thermal. The lapse rate is called "super-adiabatic" because it is much greater than the dry adiabatic lapse rate found between ground and the base of cumuli. Despite the excess of temperature the overheated air seems reluctant to produce a thermal. It waits for some trigger like the downflow from a previous thermal to stimulate activity. The downflow acts like a wedge detaching new plumes from the surface. The arrival of these wedges can often be felt as a gust of wind. Sunbathers on a typical English day may notice that such chilly gusts often coincide with the arrival of the cloud shadow from a passing cumulus. A number of thermals seem to be triggered off when the shadow from an advancing cloud comes across. One can observe this while waiting to escape from ridge soaring. If many minutes of continuous sunshine have failed to set off a thermal the arrival of a cloud shadow may do the trick. Presumably the activity is initiated by the downflow from the approaching cloud.

Lesser convergence lines

There are many days when the air is too stable for cu-nims but some feature of the wind flow produces an almost continuous line of cumulus. These are often called convergence lines and forecasters can seldom tell when or where they will develop. With sufficient observations one may find that the low level winds do really converge along a well defined line. Large scale charts may show a kink in the pattern of isobars but this usually appears after the event.

Sea breeze fronts are one type of convergence line, and satellite pictures have shown a line of cloud starting over the Cornish Peninsula where two sea breezes meet and then growing to extend all the way to London. Such convergence often makes cumulus grow far larger than one would expect from looking at the temperature trace of the latest upper air sounding. John Findlater reported an occasion when sea breeze fronts coming from different directions met over East Anglia and thunderstorms developed at the crossing points.

Thunderstorm outflows and convergence lines

The downflow from a moderate sized cumulus is negligible compared to that from a full grown cu-nim. When big cumulus reach the shower stage the mass of falling water, perhaps weighted down by hail too, can combine with evaporational cooling to produce

powerful downdrafts that reach down to the ground and spread out horizontally for many miles. In the extreme case the downdraft may be termed a microburst with storm force squalls. (The strongest gusts so far recorded from a microburst in the USA was 130 knots). More often the outflow only forms a vigorous gust front which spreads out to trigger off new shower clouds. American meteorologists have observed that thunderstorms are often initiated at convergence lines, and where two such lines collide the result may be a very severe storm. The collision of two gust fronts can set off a great fountain of rapidly rising air. Sometimes one gust front spreads out to undercut an existing storm, greatly adding to its vigour and possibly setting off tornadoes. At other times the arrival of the gust front at a range of hills is enough to set off new storms.

Developments like this are best watched from the ground or from a powered aircraft which can turn tail and get well away when conditions begin to look dangerous. Even in England, where the majority of thunderstorms are babies compared to the American monsters, the collision of two gust fronts can be followed by extremely rapid extension of the storm area.

Thermal detectors

I have not yet heard of any successful way of detecting thermals instrumentally. Very many years ago it was hoped that sensitive thermistors in each wingtip could be made to show which way to turn on encountering a thermal. In recent years some hangglider pilots have used an instrument to detect temperature gradients in the air they fly through. The device is said to distinguish between the turbulent fluctuations which always exist in thermic condition and true thermals. There seems to be some doubt if the detector really works at high levels, but at the very low levels where hanggliders begin thermalling the instrument may be helpful.

Cold thermals

The problem with any temperature sensing scheme is that thermals are only warmer than their surroundings at low levels. The original temperature difference usually disappears when the thermal rises well above the ground. Towards the top the rising air is usually cooler than its environment. This is illustrated in figure 16. In this figure the actual temperature has been converted to "potential temperature"; this is the temperature which dry air would have if it descended to the surface, (it is usually calculated for the 1000 millibar level). The advantage of the potential temperature is that you can compare the air temperature at different levels to a single standard. If the temperature follows a dry adiabatic lapse rate its appearance on this diagram is a vertical line.

In figure 16 the solid line represents the thermal rising from the ground while the dashed line is the environment temperature. The stippled area at the bottom shows the thermal starting off much warmer than the environment. This part has a super-adiabatic lapse rate. By the time it has reached about 500 feet (sometimes sooner) the thermal will have cooled to about the same temperature as its environment. The two lines overlap with only

small wiggles. Near the top where the environment becomes stable its potential temperature rises with height. (The dashed line curves off to the right.) There is then a widening gap between the temperature inside the core of the thermal and the air outside. The shaded section shows this change. Eventually this cooling stops the thermal rising any further, but it may go up quite a long way before stopping.

How moisture helps

Thermals usually carry up moisture from low levels and this acts to reduce the density of the air inside the thermal. Water vapour is lighter than dry air so humid air is less dense than dry air at the same temperature. Meteorologists find it simplifies many calculations to use the "virtual temperature" of the air instead of the actual temperature.

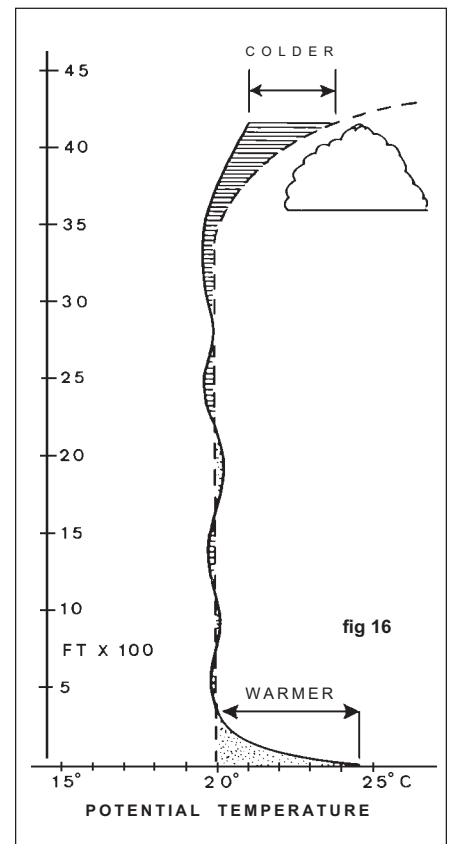

Virtual temperature

The virtual temperature is higher than the measured temperature by an amount which exactly balances this change of density. For example if the pressure was 800 millibars (6394 feet on the altimeter) the temperature 14°C and the humidity just over 90%, the virtual temperature would be two degrees higher than the actual temperature of dry air. Put in another way, the air in the thermal could be nearly two degrees colder than the dry surroundings and still have a tiny amount of buoyancy. In real life the surrounding air also contains some moisture so the difference is rarely so great but the effect is still important.

The extra buoyancy due to added moisture and the momentum of the rising air combine to help strong thermals penetrate some distance into a temperature inversion.

GROWING UP

On being there —

Graham Payne

ONE OF MY EARLIEST MEMORIES as a child is of being at the Gatineau Gliding Club's airfield at Pendleton, Ontario waiting for my father to land after a long flight.

I don't know how old I was, although I do remember that I could not then tell time. During the wait for my father's return, I was unsettled by the move of all present on the ground from the end of runway 26 to the end of runway 35. All that is, except for me. Today I know that the wind direction must have shifted, causing the change in active runways. Eventually, my lonely and fearful wait ended when my father appeared, happy after his flight, striding down the runway to collect me and the car.

Another of my earliest memories is of being up in the control tower located on top of a corner of one of the hangars. I do not know how long before the tower had stopped being used, but it was probably before the GGC bought the airfield from the Canadian government. It clearly had been long unused. Looking down on the airfield from above was a new experience. The tower had large ring-like objects against two of the walls which reminded me of the steering wheel of a car. My father told me they had been used to turn on the runway lights. Anyway, I was not left alone this time, as my father was helping to secure the tower for the winter. Today, almost 25 years later, the tower is gone.

My mother also flew gliders. I have heard her say several times that the third time she was introduced to my father occurred at Pendleton and that, after their third introduction, "... he couldn't ignore me." Indeed I seem to owe my every existence to the Gatineau Gliding Club and to the Pendleton airfield.

My mother quit flying well before her first of two children, I, was born, and then never went back to it. In contrast, my father kept on flying and used to take me out to the gliding club with him. I always looked forward to these trips. Like some young boys, I wanted with all my heart to be a pilot when I grew up and these trips were the closest I could get to actually flying. But the airfield held an additional attraction. Built during WW II as part of the British Commonwealth Air Training Plan, the Pendleton airfield had a history and an atmosphere that intrigued, mystified, and excited a young boy who wanted to be

a pilot and who read everything connected with aviation he could. Most of that material described the exploits of pilots during the two world wars. Such an attitude did have a down side, however. The knowledge gained from my reading about the air wars made me realize that a fair number of the young men who gained their wings at Pendleton died not long afterwards. I used to wonder if their souls ever returned to Pendleton. It made the airfield seem haunted at times.

As I grew older, I was able to secure for myself an important job when my Dad went to the airfield. I can't remember how it started, but I was taught to retrieve one end of the tow rope, the end that was attached to the towplane and wait for the plane to taxi back down to the runway's end where the glider waited for its tow. Then, I would eagerly run up behind the towplane, hook up the rope, run up in front of the towplane and wave it off. This job was the closest I could actually get to being a pilot and I would do it all day with enthusiasm. To this day I am proud that none of the ropes I hooked up ever came off.

Eventually, it occurred to me that there was no reason why I couldn't go for a glider flight, at least as a passenger. I badgered my father until he agreed and at about the age of 8 or 9, I had my first glider flight. I went up in a 2-33 that took off using runway 26. I remember little of that flight except that the pilot who took me up said little or nothing to me during the whole flight and my father's instruction not to look down on the lower wing while thermalling as it would make me dizzy.

I continued to dream about being a pilot until an unforeseen event occurred. Difficulty in seeing the board in my grade 4 classroom led to my first set of glasses, and the sky fell in. No one, I knew, wanted a pilot with glasses. I was very sad. My dream was gone forever. About this time my father, who had always had little vision from his right eye lost his medical permission to fly, although he had been flying for over 15 years with a very good safety record. The trips to Pendleton stopped. I was unable to visit my favourite place, a place I was probably silly in finding more exciting than my own home.

I went to Pendleton only once in my teenage years. For my 18th birthday, I asked for a glider flight as a present and it was granted. I was delighted when the pilot let me take

the controls briefly. After that came my last year of high school followed by eight years of university. With no money and under constant pressure from a difficult academic load, thoughts of flying were far from uppermost in my mind.

Finally, in October of 1988, I left graduate school and moved to Ottawa to work. I bought my first car. One November Saturday I remembered the gliding club. I knew that there would be no flying that late in the fall. Even so, I thought, I could go out and walk over the airfield and revive my childhood memories. With a bit of difficulty, I found my way out to Pendleton. To my surprise, the gate was open, so I drove in. Then, I had a second surprise. As I reached the hangar, those big hangar doors I remembered so clearly as a child were open and there were people working around the hangar! I walked up to someone and introduced myself, saying that my parents had flown at Pendleton. One of the people present even remembered my parents, and I recognized him, although I didn't remember his name. By a remarkable coincidence, I had turned up on the very day the hangar was being given a final packing and being closed up for the winter. I left

photo unavailable

AT PENDLETON

First memories to solo

with information, contact names and phone numbers, and a mounting sense of excitement that I would finally be a pilot !!!

I bided my time, and as the winter drew to a close, my thoughts turned more and more to Pendleton and flying. On the morning of April 2, I phoned the clubhouse. The phone was answered and yes, they were starting the flying that day. Giddy with excitement, I dashed to my car and sped to the airfield. The day was cold, overcast and windy. There were still patches of snow on the ground.

That memorable day the club was using the Blanik, CF-GPH to do spring checkflights for the CFI, the deputy CFI, and other instructors. They kindly found time to give me two instructional flights. I left the airfield that day very excited and ecstatic... Finally, at 27, I was learning to be a pilot!

From that unforgettable day on, every Saturday and Sunday found me happily at the airfield — flying, or crewing on the ground. As spring progressed, I bought a tent and pitched it at Pendleton, which allowed me to stay over two nights before returning to Ottawa. When the weather was bad on Satur-

photo unavailable

days and Sundays, I fretted in frustration in my Ottawa apartment, looking at the western sky every ten minutes to see if the weather was improving.

I progressed at a more or less steady, though not spectacular rate, towards solo. During my third instructional flight of the day on July 15, we thermalled to 6800 feet and I seemed to be able to do everything just right. When I looked at my progress records everything was rated as "OK for solo" except for side-slipping and crosswind landings and take-offs, which were rated as "Requires Review". Prior to that third flight I took and passed the pre-solo exam — I had certainly come a long way since April. That evening in the clubhouse the CFI, after talking to the instructor of the day, said to me, "We'll do a flight tomorrow morning and if you can do for me what you did for Jürgen, I'll let you go."

In the middle of that night in the tent, I awoke from a sound sleep in the pitch black. I could not tell if I was excited or fearful or both. Around 7:30 I awoke, pulled on some clothes, and crawled out. I walked to the clubhouse, made and ate breakfast in the kitchen and then headed for the hangar and helped to open up the hangar doors and push out both towplanes, and several gliders including the ASK-13 reserved for training, CF-AKH. I was doing the DI on AKH when the deputy CFI, Wolfgang, turned up. "Someone is keen", he said to me and grinned.

The CFI, Richard Officer, joined us on the flight line and we got into AKH and got ready to go. The takeoff, tow and free flight went well enough, as did the circuit and landing. As we got out of AKH, Richard asked for my student pilot permit from Transport Canada. It had come in the mail about six days earlier. Excited, I readily handed it over.

We pushed AKH back to the end of 26 and I waited impatiently while Richard and Wolfgang filled out the student pilot permit. Excited, but trying to stay calm and alert, trying to be a good pilot, I got into the front seat of AKH. Wolfgang took the cushions out of the backseat and tied the straps down. I did my cockpit check and then looked out on the right wing. Wolfgang was there. It seemed an honour to have the deputy CFI run the wing for me, but I was too preoccupied to dwell on it. I signalled for him to check above and behind. It was clear. I gave him a thumbs up.

The ground roll went fine and then first the glider, and then the towplane were in the air. I was concentrating too hard to care about the empty back seat. We climbed to 3000 feet and then I went through the release procedure and said farewell the towplane piloted by Simon Dufour.

I was on my own! It was sunny and hazy and at about 10 am, there was no traffic in the area. There was also no lift. I floated down to 2000 feet doing nothing special, making gentle turns, and ensuring I didn't get too far from the field. I flew over the end of 26 and looked down. A group of people had gathered there, and they were all stationary, and looking at me! At about 1200 feet I entered the circuit. On the left downwind leg, I did the pre-landing check. Once that was completed, I chose an aiming point, and kept looking at the ground below judging my height. The approach went fine and I rounded out, flared, held off, and let the glider settle gently onto the grass. We rolled to a safe stop.

I opened the canopy, undid my straps, and got out. I looked back, most of the people still stood motionless, at the same place I had seen them at from 2000 feet, staring. David Smith, a club member about my own age, was the first to greet me. He bicycled up and stopped. "This is for you, congratulations", he said holding out a mock bouquet of ragweed he had just picked.

"Ragweed makes me sneeze", I replied, shaking his hand and throwing away the bouquet.

The second person to reach me was Wolfgang. "If you were any better looking I would kiss you. Never again will you make such a smooth landing," he said shaking my hand and smiling.

Eventually we were joined by everyone on the ground. I received congratulations and handshakes all around, and didn't even have to push the glider back to the launch position! I did two more solo flights that day and nineteen more by August 19, including a two hour and thirty-three minute flight when I earned my 'C' badge.

Looking back on this past summer, the flying and camaraderie of the club have left me with many happy memories. More importantly, it has been the fulfillment of a childhood dream. ●

AEROTOW TRAINING

Larry Morrow

Winnipeg Gliding Club

DURING THE SUMMER OF 1989 I was employed at the Air Cadet gliding camp in Penhold, Alberta. Soon after the cadets arrived to begin their training, an Air Cadet towplane crashed in Princeton, BC, killing the pilot. This accident was caused by the glider pulling the tail of the towplane too high at low altitude while on a training flight. This information caused some apprehension among the cadets, who were approaching this stage of their instruction. I have also noticed while instructing at the Winnipeg Gliding Club that a student who has had an initial problem with aerotowing, ie. getting badly out of position to the point that the instructor must take control, is nervous about this phase of their training. The following notes describe an initiation procedure for student glider pilots who are at the stage of beginning to fly aerotow.

Begin by reviewing the effects of the controls with the student. Since large control movements result in faster movements of the glider, emphasize the need for small control movements and relate this to the motion of the glider relative to the towplane. On the pitch axis, large control movements result in faster vertical motion of the glider relative to the towplane with greater chance of overshooting the correct towing position. On the longi-

tudinal axis large aileron movements result in relatively steep bank angles which yield a faster relative motion and a greater chance of overshooting the correct towing position.

The next step is to demonstrate the amount of control which the pilot has over the glider. Most students' first experience of the glider being out of position on tow is during their first attempts at flying the tow. Their efforts in this period are normally concentrated on returning to the correct towing position, usually as quickly as possible. This results in large, hasty control movements and reinforces a feeling of apprehension about not being in the correct towing position. The instructor flies the glider below, slightly above and to the side of the towplane, maintaining each position for a few seconds and returning to the correct towing position before proceeding to the next one. When returning to proper position, move the glider very slowly in relation to the towplane and point out the relation between the slow relative motion of the two aircraft and the small control movements.

It is only necessary to move the glider to the side the same distance used when boxing the wake. For the low tow position the glider is just above the towplane wake. To demonstrate the high tow move only slightly above the towplane and also explain that the slow relative motion will prevent slack in the rope.

This demonstration can be done in the early stages of training while the instructor is flying the tow portion of the flight and may be repeated to reinforce the concepts. •

Comment by Ian Oldaker , Chairman FT&S

One of the important aspects of teaching the aerotow is not to start a student too early in what is a difficult part of flying; after all, we are expecting the student to do some formation flying with very little experience or skill. The rule of thumb should be to start them when they can make a well coordinated and crisp entry to and exit from a medium turn. All maneuvers behind the tug to keep in proper position should of course be by coordinated use of the stick and rudder — and demonstrating how far out of position one can get is a good idea and is best done by a clear well coordinated maneuver.

Returning to the proper height behind the tug after a divergence is now being taught like this: imagine that when the tug is at the correct position (wheels about five feet above the horizon, or where the horizon would be for hazy days or mountain flyers!) it is in the centre of a "gunsight" which is on the canopy — to allow for turns, the sight can be two inches across the canopy. All the pilot now has to do is to keep the tug in the sight. When the correct position has been regained, the glider will no longer climb or descend relative to the tug. There will be very little tendency to overshoot — try it!



FAI International Gliding Committee Report

Colin Bantin

Chairman Sporting Committee

A MEETING OF THE IGC was held in Paris on 23/24 March 1990. The meeting was well attended including a representative from East Germany (DDR). (This may be the one and only time we have a representative from the DDR!) Thanks to a new format a lot was accomplished. During this meeting we had, for the first time, a series of workshops. This enabled a lot of detailed work to be done in parallel and only summary results needed to be presented and ratified in plenary session. I elected to attend the working groups on the rules and on the future financing of the FAI.

Opening The Minutes of the October 1989 meeting in Paris were approved with the deletion of the last sentence of the first paragraph of section 4.2.1 d).

Working Groups The following working groups were established for a meeting later:

- Rules: chaired by Tor Johannessen (Norway)
- Airspace and Regulations: chaired by Tom Zealley (UK)
- New Flight Documentation Equipment: chaired by A. Deutsch (FRG)
- FAI Finances: John Roake (NZ)
- International Sporting Calendar: M. Faber (Austria)

FAI Matters IGC President Peter Ryder summarized current FAI matters.

At the Paris Council meeting in February there was a new proposal by General von Kann on novel ways to finance the FAI. These are sanction fees for holding world contest events, a new merchandizing program, and fees for services (eg. homologation). More about this later since it was the central topic of the FAI Finances working group.

At the CASI (International Aeronautical Sporting Committee) meeting there was a new definition of ultra-lights introduced. Takeoff weight, not empty weight; and minimum safe speeds, not wing loading, are to be used.

World Air Games A meeting was held at Toulouse which included the FAI Commission Presidents and local officials. There is considerable local interest and support (including money) for the first World Air Games to be held in the Toulouse area in September 1991. There was also considerable enthusiasm on the part of the Commission Presidents, except Peter Ryder. The position of the IGC is that there can be no involvement on the part of soaring if there is no support

from the French soaring association (FFVV), which until now has refused to participate.

It became apparent from François Ragot later in the IGC meeting that the FFVV has been offered a large sum of money by the organizers to set up a gliding event! (The comment was heard that now we know what we are, it is just a matter of agreeing on the price.) However, it is still not clear what will be organized for gliding at the Games, and it does not change the fact that there is too little time, and the venue and dates are wrong for holding a world level soaring competition. The IGC passed a resolution to the effect that although the IGC recognizes the value of the World Air Games for the purposes of exhibiting gliding, these Games do not meet the IGC standards for competition.

The 1991 General Conference of the FAI will be held in Berlin to commemorate the 100th anniversary of Lilienthal's first flight. It was suggested that one-time commemorative trophies be awarded for the best glider flights between 15 August 1990 and 15 August 1991. The categories suggested were speed over 300 km course, distance around FAI triangle and absolute height. It would be administered by the aero clubs. This suggestion was put into a motion which was unanimously passed.

Financial matters of the FAI were postponed pending the discussions of the working group.

Sub-committee Reports The Rules sub-committee report was postponed pending the discussions of the working group.

There is still no chairman for the motorglider sub-committee, however Peter Ryder undertook to list the present issues concerning motorgliders. Some of the more urgent considerations are how they are to be defined and how they fit into the present rules structure. Discussion was postponed until the next meeting. Reports from Airspace and Technical sub-committees were postponed pending the discussions of the working groups.

International Events Before the discussion turned to individual events it was suggested by D. Bradley (SA) that matters concerning European events could be held in a separate forum since they were of limited interest to non-European countries. There was some support for this idea (myself included) and the format for the next meeting may take this into consideration.

- Ameriglide and 22nd Worlds: Ameriglide has at present 85 entries from 22

countries with 15 standbys. The rules have only seen slight modification from last fall's submission. The distribution of points for POST tasks has been changed to 500 for speed and 500 for distance, and there has been no change to the penalty. A motion to accept the rules as is for use in Ameriglide and for the Worlds was defeated 3 to 23. A motion to test these rules at Ameriglide and modify them if necessary before the Worlds was passed 23 to 3. Although I was originally critical of the complexity of these rules, I was in favour of their acceptance at this meeting (1 of the lonely 3). It is a dangerous precedent to change the rules before a World Championships without a further opportunity to gain experience using them.

Early pre-registration will be accepted for the Worlds next fall. There is a limit of 120 pilots, 4 per country (plus 3 reserve), and a 2 per class limit.

- 23rd Worlds — Borlange, Sweden Planning is continuing for this event. There is some early indication of airspace problems, and the issue of transponders has not been decided.

- The 1990 Swedish Nationals could accept up to 5 foreign entries.

- The 1st and 2nd World Motor Glider competitions were briefly discussed.

World Class Glider There are 81 entrants to the World Class glider design competition. This is considered to be an extraordinarily high number (would you believe eight from Canada!), however a lot of them may be for interest only. The management committee for the competition met in London and discussed the timetable for events. I will distribute more information when I get it.

Other Items

- The Barron Hilton cup will be continued for another two years. SAC and *free flight* has information for anyone interested.

- The Pelagia Majewska Medal was awarded to Ann Welch (UK). There was no award for the Lilienthal Medal.

- There is no change to the officers of the IGC except that Tor Johannessen is now the 1st Vice-President.

Working Group Reports

FAI Finances This group met to discuss some financial considerations and the structure of the FAI. In a proposed policy

continued on page 20

“Puchatek”

A NEW TWO – SEATER FROM PZL

Josef Repsch

Edmonton Soaring Club

A LATE SEPTEMBER MORNING last year finds us sipping extra strong espresso in the plant manager’s office. We are in the PZL glider manufacturing facility in southern Poland and a few minutes away from the plant tour. When the tour guide arrives we receive a short introduction to the history of this factory. The plant is backed up by over 60 years of experience in the field of manufacturing aviation equipment. The first international achievements came in the early 30s when the factory was involved in the preparations for a number of major international competitions as well as for transatlantic and transcontinental flights. In 1931 Capt. Markiewicz completed his solo flight around Africa in a single engine PZL–L2. In 1933 Col. Skarzynski flew another single engine plane (RWD–5) from Senegal to Brasil and, in a non–stop flight over the Southern Atlantic set a distance record.

We glance through photo albums with hundreds of photographs and resourceful information documenting a rich and dynamic involvement of this plant in the history of Polish aviation.

During the post war times a group of devoted enthusiasts decided to rebuild the totally destroyed facility and rejoin the strive for excellence in motorless flying. Throughout the first decade they managed to come up with a number of aircraft designs that established their position amongst the world leaders of this industry. Some of us should still remember the two–seater Bocian, which in some European clubs still plays a dominant role in training of new glider pilots. The late 50s brought in the slick single seater Foka which dominated for a number of years most of the European and overseas competition events. And then there was the Jantar which until now remains recognized as an excellent aircraft amongst glider pilots.

After this impressive bit of history we move into the production facilities. We walk briskly through various areas of the plant observing meticulous efforts of workers assembling wing and fuselage components. We spend some time in the quality control lab where technicians perform wing and fuselage load tests. Our guide explains that before final assembly, the individual components of the sailplane must be exposed to a series of real time tests verifying their ability to perform under extreme flight conditions.

We try not to stay too long in the factory as the morning fog has lifted and clearing sky indicates good flying conditions. We take a short drive to the airport enjoying the rich colours of the “golden autumn”. After our arrival we take part in a short weather briefing

and safety regulation around the airport. A few minutes later I am introduced to the factory pilot who would provide me with a demonstration of the two seater. With parachutes strapped on tightly we are taking our seats in the cockpit. First a very positive surprise: the front seat accommodates very comfortably my six foot two and 220 pounds stature. After getting strapped to the seat I still maintain lots of room around my shoulders and have no problems with avoiding contact between my head and the canopy.

The pilot explains to me the features of the aircraft, performance characteristics and things to look out for while flying around this area. We have to stay on the northern side of the mountains, otherwise we would have to look for an alternate landing place in Czechoslovakia. Thumbs up and we start rolling. The roar from the AN–2 towplane cuts off our conversations in the cockpit and a suddenly discovered very short length of the tow rope transfers my attention totally to the fin of the towplane. After a few moments we are airborne and I am getting a tap on my shoulder indicating that the factory pilot has no interest in towing. The fun begins.

The airport is located very close to the city outskirts and immediately we are in close proximity to the roofs of apartment buildings and factory chimney stacks. I leave my confidence totally assigned to the towpilot and try to look for reference points on the ground through the residue of fog patches still hanging above the ground. The tow runs very smoothly, and after a few minutes of climbing we release at 3200 feet right above the peaks of a picturesque mountain chain.

The pilot leaves it up to me to decide on the first few maneuvers. The stall comes very gently with plenty of warning rumble and

with positive confidence to keep on flying even with the stick in a full back position. The sailplane responds very obediently to dutch rolls and steep turns. For spins and dives we have to be a bit higher so we try to scratch a few rising thermals to gain the altitude. At 4000 feet we are already above the cloud base. Now a surprise: glider flying in clouds is allowed! But I couldn’t take advantage of the situation, being totally unfamiliar with the procedures, and transfer control to the pilot.

Shortly we are at a comfortable 6000 feet in steady climb with more time to look around the scenery down below. The canopy provides an almost unobstructed view in the front seat to both sides of the sailplane without “rubbernecking”. I have no trouble in taking a few photographs of the colourful slopes.

Since stronger winds at altitude have drifted us away from the airport we head back to leave some room in our flight schedule for more advanced aerobatics. Finally the clouds are left behind and we prepare for aerobatics. The loop, stall turn, inverted turn, spin, and spiral dive performed by the factory pilot went very smoothly and with a minimal movement

continued on next page

Technical data

For advanced and basic training, including aerobatics. All metal except fabric wing trailing edge and control surfaces. Top and bottom spoilers, fixed wheel with shock absorber and disc brake, one–piece canopy, nose & cg hook. Very good stall and landing characteristics.

Empty weight	335 kg (740 lbs)
Gross weight	540 kg (1190 lbs)
Wing span	16.4 m
L/D _{max}	27:1 @ 46kts (85 km/h)
Min sink	154 ft/min (0.78 m/s)
V _{stall}	32 kts (59 km/h)
V _{min sink}	40 kts (75 km/h)
V _{max aerotow}	70 kts (130 km/h)
V _{ne}	111 kts (205 km/h)
g limits	+5.3 to –2.65

photo unavailable

A general view of the KR–03A. The constant chord wing and high canopy line are notable.

SAC AFFAIRS

"SAC AFFAIRS" is a new feature beginning in *free flight*, in which it is hoped regular and current reports from directors and committee chairmen will keep us better informed about the on-going work the organization does on our behalf. editor

INSURANCE

Each year we try to conclude discussions with the broker, obtain approval from the Board and advise the clubs well in advance of the March expiry date. Rates depend on a number of factors, our loss ratio being but one. There is some volatility in the aviation insurance industry that extends beyond the Canadian market which was a factor in some late discussion that delayed the process this time.

However, the end result is an attractive package from our existing broker and insurer, with whom a very satisfactory relationship exists. You will recall that '89 rates were down approximately 12% from the year before, with more benefits. This year the policy is unchanged, with premiums reduced 5%. In addition, as at March 31st, 1991 there will be a rebate of approximately 10% which you may apply to '91 premiums, or take as a refund.

From time to time coverage is offered by other sources, usually to pilots with high experience levels and no previous claims. Factors to consider include:

- what are the deductible amounts?
- check exclusives, eg. is contest flying allowed; does coverage extend beyond Canada; etc.
- usually the pilot, rather than the aircraft, is covered and so the insurance may not be suitable for clubs or syndicates
- claims services – where from and how managed
- if you have a claim, will similar coverage be available next year?
- track record of the broker and insurer
- is the price better after allowing for variables?
- SAC has a good rapport with the broker and can frequently facilitate handling of special requests and situations.

We understand our US counterparts would welcome a scheme similar to SAC and our best chance of continued superior service at fair prices is through the widest possible support by members.

The dollar amount of claims in '89 showed improvement, and from perusing accident/incident reports, it is apparent that careful attention to pre-flight checks, and circuits properly flown to landing will contribute to even better results this year.

Some provincial associations and government funding bodies wish to be provided with liability coverage. We propose to accommodate this by including these groups, on a needs basis, as "additional named insureds" for cover under the Aircraft Liability section and Premises Liability section of the Airport General Liability Policy. This means all named insureds would share coverage under the relative sections. We believe this would still provide reasonable cover for the clubs and SAC and at no additional cost. If there is interest, future articles may address what is involved in getting the scheme in place each year and the purpose and objectives of the minimum hull values list. Meanwhile, questions and suggestions are welcome.

Bryce Stout

Chairman Insurance Committee

BC REPORT

On March 10, 1990 the Vancouver Soaring Association has officially started its 1990 soaring season, by assembling a Blanik in the rain at Fort Langley and starting "season start proficiency check flights" in the sailplane and in the L-19 towplane. Unfortunately some thieves dampened our enthusiasm last week, by absconding with two Blanik tool kits and tiedown straps for the trailer. Not a very nice welcome by some locals!

On a somewhat better note, I am pleased to report that a local radio station has carried an interview with yours truly, and as a result of a conversation with the interviewer a local weather forecaster got in touch with me. He is very enthusiastic at the prospect of chairing the Meteorological committee. I ... will

since it was done without any extensive instructions or any previous experience.

Trying to get back to the airport, I suddenly realized that this aircraft's glide ratio will not let me to complete the landing pattern in the same manner as in our club's Blanik. We still have lots of height to kill and so decide for a very long sideslip lasting the entire length of the downwind leg. Back on the ground half way past the landing strip confirms once again my underestimation of the sailplane's performance.

keep you posted of our progress, so that you can officially welcome him when the time comes.

On a still lighter note: spring has sprung here with its usual abundance of flowers and blooming trees and shrubs. Have a good season!

Harald Tilgner

Pacific Zone Director

ONTARIO ZONE

Due to a fairly mild first three months of the year, the Ontario soaring season has gotten off to an early start. SOSA started operating on 1 January and followed up with some other flying days in January. At Pendleton, the soaring season got under way on 24 March with about twelve flights.

The Canadian Advanced Soaring Group organized a one day cross-country workshop at Hawkesbury on 17 March. It was attended by about 35 pilots and featured lectures on thermalling, decision-making, the Chief Soaring Instructor concept and a slide presentation by André Pepin about flying in the mountains of France.

CASG — in the person of Ed Hollestelle — also gave a half-day cross-country workshop in conjunction with the Ontario Soaring Association annual general meeting on 24 March in London, Ontario. It also was attended by over 30 pilots. Ed managed to sign up 13 pilots for the CASG cross-country clinic in late August at SOSA. This looks like it will be a very popular event and follows on the successful clinic done last year at York Soaring.

Many pilots are off to Pennsylvania to try ridge soaring. Walter Weir went even further south, to Tennessee. We will get a full report from him soon. Others are making plans to go to the popular Chester Regionals in South Carolina or are just getting their sailplanes ready. Clubs are reviewing their equipment and wondering how to get maximum use and enjoyment out of it. The high value of the D-Mark is making the purchase of new equipment difficult. Clubs should also be reviewing their member recruitment strategies. SAC has information available about ideas on how to publicize soaring at the club level. Contact the National Office.

Ulli Werneburg

Ontario Zone Director

This airplane flies well and provides lots of patience and understanding to less experienced pilots. On the way back from the airport, without hesitation I committed myself to bring the KR-03A to Canada. The powerful prairie cumulus should be able to indulge its performance to an even greater extent. •

At time of writing, importation costs are unknown so the total price is not certain. It is expected to be somewhat more than \$25,000. Contact Josef Repsch (ads on p23) for more information. editor

Puchatek continued from previous page

of controls. I am going to try the same program by myself. Hurray! The loop is completed and even its irregular shape does not remove the satisfaction of a fast learning experience. Stall turn comes as easy. After this one, I am not sure if I am not getting any assistance from the pilot sitting behind me. He confirms he is not. I then try a spiral dive and a spin, bringing the aircraft to a normal flight pattern almost effortlessly. I am very impressed with my aerobatic feat, especially

Hangar Flying

TWO 1-26 ASSOCIATION RECORDS SET AT COWLEY

Dave Mercer, of the Regina Gliding and Soaring Club, set two new 1-26 Association Regional records at Cowley last year. This is how Dave describes how it went:

Franz and I arrived in Cowley, Alberta the 7th of October with 1-26 "068" in tow under wave conditions. Franz and I rigged her and then waited for the Regina club's Twin Grob to get there for an area checkout. I checked out Franz (my co-driver from Regina) and managed to get to over 16,000 feet in moderate wave in the Grob. We had to pack it in for the day so 068 did not get wave that day.

The next morning dawned with lenticulars abound, so we crammed breakfast down and drove to the field. I hopped into 068 and again got to just over 16,000 feet. Gold climb, but I needed the diamond! Franz was next, and on his first solo wave flight, and the flight before being license-qualified, got to over 20,000 feet in 068! He was short of diamond altitude by just a little bit but unfortunately was carrying no barograph through no fault but his own (he didn't want to put it in for some reason or another). When he got down we put it in anyway and sent him up again, but he was unable to connect at all.

We went back to the hotel hoping conditions would continue to improve. They did. When I woke up, I didn't hear the window rattling like the morning before, so I didn't bother opening my eyes, let alone get up and look outside. After about 20 minutes of trying to mentally levitate both myself and my bed to the shower, Darren Grant and Mark Lawrysyn began yelling and pounding on the door to get up and look at the terrific lenticles. Being the jokers that they are, I figured that it was overcast and raining or something, but they were true to their word. I was out the door in 30 seconds flat. Darren, who has been looking for a diamond for ten years at Cowley and never ever seen wave until this year, hummed and hawwed while glancing between his watch and the sky (read lenticles). Finally he decided that he really had to get on the road to Vancouver (a twelve hour drive). My deepest sympathies to him. I got in his place, contacted secondary wave on tow at 1500 feet, released, notched, and began to climb at just under 2000 feet per minute — and then the gripping realization hit me. My barograph! I forgot to turn it on! I pulled the spoilers at 10 and a half a grand, moved to the downside of the wave, and was down 15 minutes after first rolling.

I got sorted out, and repeated the same process as the previous flight except releasing 1400 feet agl this time. At 17,000 feet msl I advanced to the primary losing only (!?) 4500 feet penetrating. Now began the climb above stacks of lenticles all the way up to just

below 26,000 feet. I was stopped by an overcast that formed 20 miles ahead from the Great Divide. At one point I was wedged between the top of one lenticular (the third in the stack) and this overcast base above, which I found exhilarating and eerie all at once. Still climbing at 400 fpm, I was beginning to get icing as I drew within arm's reach of the overcast, so being low on oxygen and wanting someone else to experience what I experienced because I was going no higher, 068 and I headed for home. That old girl, who's at least a dozen years older than I, still had it in her.

The altimeter and barograph were found to have had over 3000 feet of altimeter error, therefore the final approved altitude (22,450 feet and a 16,733 gain) is well below what it was anticipated to be, but it's a diamond!

GROUND EFFECT

For powered aircraft, ground effect can extend range or the power required to stay airborne significantly by reducing drag when very close to the ground. This was discovered years ago by the captain of a Boeing Stratocruiser between Honolulu and San Francisco after he lost two engines on one side due to a runaway propeller and was unable to maintain level flight until he was just about to ditch in the Pacific. At wavetop height he flew for hundreds of miles until the fuel load was burned off sufficiently to allow the flight to proceed to land at a less precarious altitude. The dramatic discovery Tyson made about the performance characteristics of an aircraft at extremely low altitude was so profound that the phenomenon was named after him: the T-effect, which after being fully investigated and explained, became known as the ground effect.

For gliders, the only time ground effect, or the ground cushion as it is sometimes called, comes into play is in the early takeoff and final flare and landing portion of a flight.

The performance enhancement comes as a result of a reduction in the induced drag of the wing when it is close enough to the ground to have the upwash in front of the wing and the downwash behind it, and the consequent wing angle of attack, reduced by the presence of the ground. The diameter of the wingtip vortices are also reduced when the wing is flown near the ground which reduces the induced drag (creating the same effect as increasing the aspect ratio of the wing). Close is very close — there is little significant effect until the height of the wing above the surface is less than about 40% of the wingspan (see the table for the variation of induced drag with wing height).

Since the effect acts on induced drag (which may account for as much as 80% of total aircraft drag near stall speed), it explains

why it has less significance for high winged aircraft which can't get the wing low enough, for sailplanes which have a proportionately smaller amount of total drag as induced drag due to the high aspect ratio of their wings, or for any aircraft flying at a low angle of attack (higher speed) when induced drag is reduced.

Ratio of Wing height/span	% of free air induced drag
1.0	98
.90	97.5
.80	97
.70	96
.60	94
.50	92
.40	87
.30	81
.20	71
.10	52

What does this all mean for the glider pilot? Well, it's great for drifting down the runway while aiming for the target in a spotlanding contest, but it's lousy for expecting that it will save your butt if you have got yourself into an undershoot situation and tried diving into the ground effect. (Several studies have proved that it is always better to maintain the glide path at the best speed to fly, and if that won't get you home, land somewhere else.)

adapted from an article in *West Wind*

THE BIGGEST, LONGEST "MURPHY" OF ALL

At the end of April this year a glider delivery trip was arranged to take a DG-200 sold to a Montreal pilot, Gilles Séguin, from its Claresholm Alberta storage location, to the DG dealer at Hawkesbury, and return with a repaired DG-202 to Edmonton.

The driver, who shall remain nameless, picked up a DG trailer at Claresholm on Thursday, April 26 and headed off on the 4000 km trip east. On the Monday morning the glider arrived at Vankleek Sailplanes where Günther Geyer-Doersch immediately noticed that the trailer was strange — the driver had hitched up the WRONG trailer and hauled a DG-400 owned by Rick Ryll across the country — and was then faced with the prospect of three more 4000 km trips to get all gliders reunited with their owners!

... a great story travels fast, and this one is probably now known to every glider pilot in Canada within the month this issue of *free flight* was being prepared, but we must record it for history. The hapless driver will become a legend in his own time, and the event will surely rank high in the international mythology of soaring — right up there with the long retrieve years ago in England to get to an outlanded Olympia at dark, only to find another Olympia in the trailer when the ramp was lowered...

Tony Burton

Club News

THE BEST EVER OPEN HOUSE

It was interesting — interesting to try and keep hundreds of people off the runway, interesting to fly more familiarization flights in one day than all that were done the previous year — interesting but exciting. The Edmonton Soaring Club's open house was the most successful ever in the history of the club. Over 300 people attended and 75 familiarization flights were sold and 65 were flown.

ESC was looking forward to a bad year with our Super Cub almost timed out, debentures due in November, and the real good news the week before was that the Pawnee was turning what we thought was a perfectly good engine into shavings (seems the chrome rings in the chrome cylinders were eating each other). We needed members and cash, and it was decided a different approach was needed to the open house than what had been done in the past.

Previously it had been held in town, generally on a weekend night with movies, donuts, and coffee. Attendance last year had been an all time low of 25 people. So it was decided to take a chance and hold the open house on the field, 45 miles from town, as it would allow us to offer rides and show off our facilities. If the people weren't interested in coming out to the open house it was doubtful they would come out as club members.

All newspapers, magazines, cable companies, radio stations, TV stations, airports, aircraft service organizations, and local bulletin boards were supplied with posters and two written notices. This was accomplished with the use of a computer data base that has been developed over the last two years. Also, every club member was supplied with five posters and asked to place them in visible locations.

It was advertised that the people were welcome and that rides would be available, weather permitting.

In order to make sure the members were at the field in advance, a pancake breakfast

was organized starting at 10 am. All club members were supplied with special badges so they could be readily identified by visitors, and the area was well signed to direct the visitors through a welcoming area.

All visitors received a name tag, and their names, address and phone number were again entered into a data base for follow up. Money for rides was taken, tickets handed out and all visitors rated as to their potential as club members. A white board was visible that listed all club fees and other information in one vain attempt to save voices.

Rides started long before the 1 pm listed time and the 1 pm general meeting didn't start until 2 and everyone was more interested in looking at real gliders rather than hearing people talk about them. The club was thrilled.

Some club members sat in the back of the 2-33 for 12 to 15 flights without a break. Heroic above and beyond the call. Our 2-33s, a Blanik, and the Alberta Soaring Council's Twin Grob were towed by the club's Pawnee and Super Cub. The ASC towplane PCK was also used extensively.

Aircraft arrived from up to 200 miles away. Two helicopters, a Pitts, a Skybolt, and a Stearman also came in to help keep the visitors interested while they waited for up to three hours for a ride.

What will the results be? Wait for next issue and we will update the results. From a strictly monetary point of view, the day generated in excess of six thousand, with three thousand from fam rides alone. That warms the cockles of a Treasurer's heart.

The weather was great, but one day either way and the results would have been different ... for once we got a break. Everyone in the club was pleased, but no one wants another open house until next year.

Dave Puckrin
ESC President

Open house photo unavailable

photo of Owen with
pile of money

Treasurer, Owen Beattie, with warmed heart.

WHERE'S ALL THE CLUB NEWS?

What's happening on the club scene in this country? It's hard to tell as free flight doesn't get much of anything from many clubs. Even if clubs wrote about their notable activities only once a year it would be a fine improvement in feedback to all SAC members. Let's especially hear from the following clubs, which haven't contributed in the last 5 years (don't be smug if you aren't listed, very few clubs have reported more than once in that time):

Aero Club des Outardes, Ariadne, MSC, Mont Valin, Arthur Gliding Club, Base Borden, Gatineau, Guelph, Huronia, RVSS, Toronto, Windsor, Saskatoon, Swan Valley, Grande Prairie, and ASTRA.

editor

NEW RED DEER CLUB

Alberta glider pilots welcome the formation of a new club at Red Deer, the Central Alberta Gliding Club. A group of 24 air cadet instructors, power pilots, and others have banded together to buy and renovate an old 2-22 in order to get some soaring going between Calgary and Edmonton. It is a welcome addition, first because Red Deer was one of the founding clubs of the Alberta Soaring Council, and second because smaller clubs have been having a rough time surviving in the province. CAGC will be flying at Innisfail airport, which now has excellent wide grass strips inside the paved runways, and for many years was the site of the Victoria Day Meet and provincial contest.

Their plans are to start simply and get many checked out to solo and licence status this year, then grow by adding a single seater. CAGC was granted interim membership in SAC at the last Director's meeting. The best of success to you all!

Tony Burton Alberta Soaring Council

IGC REPORT

continued from page 15

statement, Gen. von Kann is trying (yet again) to raise additional money for the FAI. The position of the IGC working group is that we are definitely against the concept of sanction fees for holding world contest events, in favour of a new merchandizing program, and in favour in principle of a fee for services. However, the use and distribution of the monies raised from these endeavours should be more directly under the control of the IGC Commissions. This could be arranged by having voting privileges for the Commission Presidents. The general meeting agreed with the working group's position and the following motion was passed: John Roake will prepare a discussion paper by the end of April and circulate it, through Peter Ryder, to the Commission Presidents for their meeting in June. If required the matter will be brought before the FAI meeting in October.

Airspace and Regulations

The Airspace working group agreed to prepare a position paper on the use of transponders in gliders, reflecting the practical and cost concerns. The paper will be forwarded to André Dumas for distribution with ICAO.

Rules

The working group on Rules agreed on a new Annex A to the Section 3, Class D — Gliders, which contains the rules for World gliding contests. I will distribute these rules as soon as I get a new copy since the one I have was heavily marked up during the discussions.

International Sporting Calendar

A general discussion was held regarding the number and frequency of IGC sanctioned events. The World Championships should continue at two-year intervals on odd years, with the European Championships at two-year intervals on even years. In addition Feminine, Motorglider, Junior and Club Championships should also be at two-year intervals. The so called pre-Worlds should be dropped, although an organized but unofficial event may be held at the intended sight for the upcoming Worlds. This last issue was addressed by myself and received considerable support. There was no mention of the World Air Games! (It is interesting to note that the FAI statutes list the World Air Games ahead of the World Championships). The Worlds require a site decision four years in advance, all others two years in advance. Rules approval should be one year in advance, and invitations sent eight months in advance. Decisions on all these issues will be made at the next meeting.

New Flight Documentation Equipment

The use of electronic barographs was discussed. Further study is required before they can be completely approved. The general meeting agreed that they can be authorized by individual countries for internal use for flights up to 500 km long and heights up to 5000 metres.

The next meeting of the IGC will be held in New Zealand on 15/16 March 1991. •

OPINIONS

continued from page 5

TROPHIES, TRAVEL, TRUST FUNDS

— SAC awards the Roden Trophy to the club that made most efficient use of the aircraft during the preceding year. They use a complicated formula to determine the winner which tries to compensate for the difference in the number of aircraft owned by each club. This should give a small club the same chance to win as a large club, but it doesn't work. A small club hardly ever wins, while SOSA, MSC, and York have each won many, many times because no amount of mathematical jiggery-pokery can compensate for the fact that these "mega-clubs" operate seven days a week.

Why can't we create a "level playing field" where every club has an equal chance to win? This trophy was intended to encourage clubs to plan their fleet expansion wisely and hence achieve high utilization. The big clubs have demonstrated their ability to do this, that's why they are big. What is the solution?

I suggest that the SAC Board immediately take SOSA, MSC, and York out of the game by declaring them ineligible to win. SAC could send each of them a tasteful scroll, suitable for framing, that they can hang in the clubhouse. It would congratulate them for winning so often, applaud the leadership they have given smaller clubs, and generally butter them up. It needn't even mention that they have seen the Roden Trophy for the last time.

— SAC members travelling by RV in southern Ontario are invited to spend some time at the SOSA Gliding Club. We don't have hookups but there is a dump station nearby and there are toilets and showers in the clubhouse. You can fly at regular club "O Plan" rates. There are at least a dozen gliderports in southern Ontario at which you would be equally welcome, and many more scattered across Canada. Why don't you get out your Soaring Directory right now and start planning your itinerary?

— Pioneer Trust Fund. Gordon Bruce and Ulli Werneburg have both recently referred to this as the Pioneer fund. Getting the name right is more than a matter of semantic nicety. This fund was set up in 1984 by means of the Pioneer Trust Deed. That makes it a trust fund and subject to the various laws governing such funds. The intent was and is that any money donated to this fund will stay in the fund forever. As the principal grows the income it generates will provide a dependable source of funds for the SAC that is not dependent on government grants or membership levels. To spend the principal would, of course, defeat the whole purpose. That's why it's a trust fund — and it makes me nervous when Directors forget that important second word in the title.

Dixon More SOSA

Don't forget that a \$1000 gift to the Pioneer Trust Fund still earns the donor a tax receipt and a lifetime membership in SAC. Tony

CANADIAN ADVANCED SOARING GROUP NEWS

Chairman	Treasurer
Ulli Werneburg	Nick Bonnière
1450 Goth Avenue	45 Carmichael Court
Gloucester, ON K1T1E4	Kanata, ON K2K1K1
1-613-523-2581	
Secretary	Newsletter
Elisabeth McCollum	Vicky Stamison
Box 259, RR 3	RR 2, Hammond, ON
Manotick, ON K0A 2N0	K0A 2A0
1-613-692-2227	1-613-487-2469
	fax 613-487-2855

"A CURE FOR MARCH"

March is the worst month of the year for most soaring pilots, at least around Ottawa. It's been four months since you last had a flight, winter still has a death grip on the airfield, and the close camaraderie shared with your soaring buddies seems so far in the past. The accomplishments of past years seem to be fading. What is most needed in March is something inspiring to kick off the coming season. It probably took me a nanosecond to decide to attend the CASG cross-country workshop in Hawkesbury on March 17. Despite the foggy, dreary weather, about thirty pilots attended, representing MSC, GGC, Champlain, and RVSS. Pilot experience ranged from novice to seasoned competitor.

Ulli Werneburg began the workshop by explaining why the CASG was formed. Among other aims, the group promotes cross-country soaring for all pilots, not just badge-seekers and competitors. CASG feels that cross-country soaring presents an open-ended set of goals that continue to challenge a pilot, sustaining interest and enthusiasm in the sport. It also emphasizes that soaring should be enjoyable. These two points were the keys of the workshop.

The introduction was followed by a discussion on effective thermalling. I think most pilots see thermalling as the key obstacle to overcome on the way to cross-country soaring, so the opportunity to discuss this with pilots who have mastered it was a treat.

It was suggested that an experienced soaring pilot coach thermalling novices by radio in flight. Using an audio encourages safer flying because it permits the pilot to maintain a good lookout while climbing. I don't know about other clubs, but no club ship at RVSS has a radio, and only one has a functioning audio vario. While the radio may be a nicety, I consider the audio to be a safety necessity.

Next, John Bisscheroux of MSC presented a short paper on the twin concepts of the Chief Soaring Instructor (CSI) and Soaring Training Group (STG). Proponents have recognized that there exists a void in pilot support from just after a pilot goes solo until the pilot reaches a certain level of competition flying. A lot of pilots stagnate when left on their own in this void and end up leaving the sport. MSC has created the CSI position and estab-

FAI Badges

**Larry Springford, 45 Goderich Street
Kincardine, ON N2Z 2L2 (519) 396-8059**

The following Badges and Badge legs were recorded in the Canadian Soaring Register during the period 1 January to 30 April 1990.

SILVER BADGE

791	Roger Harrop	Air Sailing		
792	Robert Lepp	Toronto Soaring		
793	Denis Bergeron	Outardes		
794	Albert Sorignet	Outardes		

GOLD DISTANCE

Gaetan Page	Quebec	307.5 km	Ka6E	St-Raymond, PQ
-------------	--------	----------	------	----------------

GOLD ALTITUDE

Merrick Dawe	Edmonton	3415 m	Libelle	Cowley, AB
--------------	----------	--------	---------	------------

SILVER DISTANCE

Roger Harrop	Air Sailing	63.5 km	ASW-20	Belwood, ON
Robert Lepp	Toronto SC	82.5 km	Ka6	Conn, ON
Denis Bergeron	Toronto SC	80.0 km	Ka6	Conn, ON
Denis Hinton	Outardes	56.0 km	1-34	St-Esprit, PQ

SILVER ALTITUDE

Roger Lepp	Toronto SC	1430 m	Ka6	Conn, ON
Denis Bergeron	Toronto SC	1220 m	Ka6	Conn, ON
Jean-Marc Surprenant	Champlain	1800 m	1-26	St-Antoine, PQ
Alain Bouliane	Outardes	1130 m	K8B	St-Esprit, PQ

SILVER DURATION

Robert Lepp	Toronto SC	7:08 h	Ka6	Conn, ON
Mark Winnett	Erin	5:11 h	1-26B	Grand Valley, ON
John Burke	York	5:22 h	Phoebus B	Arthur, ON
Denis Bergeron	Toronto SC	5:32 h	1-26	Conn, ON

C BADGE

2223	Robert Lepp	Toronto SC	7:08 h	Ka6	Conn, ON
2224	Edward Long	Guelph	2:02 h	1-34	Ariss, ON
2225	Richard Avery	Guelph	1:22 h	1-26	Ariss, ON
2226	Angus Magrath	Guelph	1:34 h	1-26	Ariss, ON
2227	Joe Labranche	Guelph	1:16 h	1-34	Ariss, ON
2228	Keith Billings	Guelph	1:05 h	1-34	Ariss, ON
2229	Ernest Bieman	Guelph	1:35 h	2-33	Ariss, ON
2230	Mark Winnett	Erin	5:11 h	1-26E	Grand Valley, ON
2231	Denis Hinton	Outardes	5:14 h	Blank	Mandeville, PQ

lished the STG to correct this situation. It appears the MSC program for post-solo pilots fully complements the usual pre-solo training. Key ingredients include lectures on relevant topics, a peer support group and daily pre-flight meetings to discuss achievements, safety issues and weather conditions for the day. My first impression of the concept was that this was just what a good number of RVSS members need, but that there isn't anyone qualified there to be a CSI, but that even in a club as small as us, a stripped-down version of the STG could work.

After lunch, Ulli and Robert DiPietro focussed on decision-making during cross-country flights, using one day's competition flying at Minden as the sample. Taking turns, each pilot carried us through his flight, describing the conditions, possible alternate actions and the decisions made, good and bad. It was valuable to be able to ask questions, and have explained where different decisions might have resulted in better performances.

The workshop ended with a couple of videos, one of which showed the building and testing of the ASW-24, and a spectacular slide show by André Pepin of Champlain of a visit he made to the French Alps near Grenoble. Combining stunning scenery, beautiful aircraft, and masterful photography, he showed us a side of soaring we rarely see.

On the way home I realized my soaring priorities had changed. The workshop had cleared away the winter blahs and replaced them with a fresh set of goals and ideas. Without a doubt, this was the sign of a very successful workshop, and on behalf of all participants, I'd like to thank the organizers for a fine job.

Bruce McGlashan, RVSS

Sedgwick James

ad

NOTE

De nouveau, il existe une Formulaire de demande de certificat (FAI) et de Brevets (FAI Gliding Certificate and Badge Claim Form) en français à cause des efforts de Albert Sorignet de l'Aéro Club des Outardes. On peut demander ces formulaires du Bureau Nationale de l'ACVV.

RECORD CLAIM

400 km Δ Speed – Open, citizens, 111 km/h, 27 April 1990, Walter Weir, ASW-20B, C-GGWW. Flown from Bedford to Keating VOR to Williamsport (departing from Ridge Soaring. Exceeds previous territorial record of 99 km/h set by John Firth in 1988.

The Ontario Soaring Association also held a half day CASG workshop headed by Ed Hollestelle, enthusiastically attended by about 35 persons who were mostly at the post-solo, post-licence stage and had not yet got their feet wet with cross-country flying. The format followed was basically as detailed above with slight changes in topics.

It is easy to set up a one day or half day workshop! Lecture notes, films, and technical advice are available to anyone in Canada by making a phone call to the CASG executive. These sessions are guaranteed to be a hit with people who have completed their licensing requirements but are unsure about how to proceed to the next phase, namely cross-country flying. Instructors who attend can treat the clinics as a "Master Coaching Clinic" where they can learn training tips, techniques and strategies that will influence the skills and attitudes of their students!

SAC TROPHIES

THE HONOURS AND AWARDS ARE THERE, BUT HOW MANY FLY FOR THEM?

Harold Eley

Trophies and Claims Chairman

ONE MANDATE OF SAC is to encourage soaring competition and excellence at all levels, and to that end a number of awards are offered annually in addition to FAI badges. Because you may not be aware of what is available to you and your club, I would like to outline what is "out there" and hope that this year you will "go for it".

First of all we have the Nationals where competition is held in several categories including Standard class, 15 Metre class and Open class. If sufficient interest is shown, a Sports class category may be included where lower and higher performance sailplanes compete together with a handicap factor to even out the competition. Many trophies are up for grabs; in fact as many as thirteen in all if all classes compete. A team trophy is provided if you want to share the competition with another pilot, and a novice (first time) pilot can try for the SOSA award. Details have to come from the contest director, but perhaps there is something out there for you.

SAC also presents a number of awards for performance at the club level. There are trophies for instructors (Walter Piercy award); Safety for a club or an individual (Hank Janzen award); recognition of contribution by a married pilot (Ball and Chain trophy); best use of club equipment (Roden trophy). Information for determining the winners comes from year end statistics submitted to SAC by the clubs and by recommendations coming from the CFIs. Do your part, let everybody know what a great job your club officials are doing, and make sure the year end numbers get into the National Office.

Finally, SAC has a number of trophies based on flight achievements throughout the year. These trophies include the prestigious BAIC for the best flight of the year; the Canadair for the best five flights; the "200" for the best five flights by a pilot having less than 200 hours of soaring experience at the start of

the year; and the Stachow for the highest wave flight with a 5000 metre minimum gain. The rules of these trophies are shown on the SAC Trophy Nomination Form which you can obtain from me (Harold Eley) or from the National Office. Your club Senior Official Observer should also have copies.

In general, trophy flights must conform to FAI rules. A barograph need not be carried except for the Stachow trophy. Turnpoints must be photographed; photos do not need to be submitted, but applications should be verified by an Official Observer. Handicaps are applied so that even the lowly 1-26 with a factor of 0.72 can have some chance against a Ventus with a factor of 1.08. Points are awarded for distance, and substantial bonus factors are applied for speed and turnpoints achieved, so it is worthwhile to declare goals or turnpoints whenever you can. Flights made at contests including the Nationals can be entered as trophy flights and documentation is easy if you fill the forms out right at the meet. With the Nationals in Starbuck this year there should be opportunities to pick up some good flights for these trophies.

For the younger pilots we also have an award called the Jonathan Livingston Seagull trophy which goes to the youngest pilot earning a Silver badge during the year. For those budding pilots just coming on stream this is your chance!

In addition to all these trophies we try to recognize "Significant Flights" with a nice certificate. These are for especially good flights, or flights which were unique because of special circumstances or difficulties surmounted.

Now is the time to think about trying for an award this year. The best months are usually May and June, which are here now. And I need to hear about all these flights and need to get information if the awards are to get to their rightful winners. Let's get to it! •

Bay. Visiting glider pilots welcome. For info call DB Munro (519) 599-6039.

Aug 6-11, **CASG XC Clinic**, MSC, Hawkesbury, ON. Limited enrollment, \$80 (\$100 for non-CASG members). Robert DiPietro (514) 659-6482.

Aug 19-25, **SAC Western Instructor School**, Chipman, AB. Course director Mike Apps (403) 436-9003. Register with National Office or Mike early!

Aug 27-Sept 1, **CASG XC Clinic**, SOSA, Rockton, ON. Limited enrollment, \$80 (\$100 for non-CASG members). Ed Hollestelle (519) 461-1464.

Oct 6-13, **Cowley Wave Camp**, a week-long event again in 1990 to guarantee a wave. Contact Tony Burton (403) 625-4563.

SAC DIRECTORS & OFFICERS

PRESIDENT and DIR.-AT-LARGE

Chris Eaves (1990)
185 Canterbury Drive
Dorchester, ON N0L 1G3
(519) 268-8973 (H)
(519) 452-1240 (B)

ONTARIO ZONE

Ulli Werneburg (1989)
1450 Goth Ave
Gloucester, ON K1T 1E4
(613) 523-2581 (H)

VICE-PRESIDENT & PACIFIC ZONE

Harold Tilgner (1990)
90 Warrick Street
Coquitlam, BC V3K 5L4
(604) 521-4321 (H)
(604) 521-5501 (VSA)

QUEBEC ZONE

Alex Krieger (1989)
1450 Oak Avenue
Sillery, PQ G1T 1Z9
(418) 681-3638 (H)
(418) 656-2207 (B)

MARITIME ZONE

Gordon Waugh (1989)
5546 Sentinel Square
Halifax, NS B3K 4A9
(902) 455-4045

ALBERTA ZONE

Al Sunley (1990)
1003 Keith Road
Sherwood Pk, AB T8A 1G2
(403) 464-7948 (H)
(403) 453-8330 (B)

DIRECTOR-AT-LARGE

Gordon Bruce (1989)
154 Shannon Pk,
Beaconsfield, PQ H9W 2B8
(514) 697-1442 (H)

PRAIRIE ZONE

Paul Moffat (1990)
1745 King Edward Street
Winnipeg, MB R2R 0M3
(204) 633-5221 (H)
(204) 947-9400 (B)

EXEC SECRETARY

Nancy Nault
306 - 1355 Bank Street
Ottawa, ON K1H 8K7
(613) 739-1063
Fax (613) 739-1826

TREASURER

Gordon Bruce

COMMITTEES

AIR CADETS

Gordon Bruce
154 Shannon Pk,
Beaconsfield, PQ H9W 2B8

METEOROLOGY

vacant

AIRSPACE

Dave Baker
12546 22 Avenue
Surrey BC V4A 2B7

SPORTING

Colin Bantin
1374 Avenue Road
Toronto, ON M5N 2H4
(416) 483-9608
Mbrs: Robert DiPietro
Wlff Krueger
Al Sunley
Hal Werneburg
Ulli Werneburg

FLIGHT TRAINING & SAFETY

Ian Oldaker
142 Mill Street
Georgetown, ON L7G 2C1
Mbrs: Mike Apps
Geo. Eckschmiadt
John Firth
Fred Kisil
Alex Krieger
Paul Moggach
Richard Vine

CONTEST LETTERS

Robert Binette
1034 St-Denis
Montreal, PQ H2X 3J2

FAI AWARDS

Larry Springford
45 Goderich Street
Kincardine, ON N2Z 2L2

FREE FLIGHT

Tony Burton, Box 1916
Claresholm, AB T0L 0T0

FAI RECORDS

Russ Flint
96 Harvard Avenue
Winnipeg, MB R3M 0K4

HISTORICAL

Christine Firth
23 Barette
Hull, PQ J9A 1B4

STATISTICIAN

Randy Saueracker
Box 2620
Medley, AB T0A 2M0

INSURANCE

Bryce Stout
2244 Belfast Crescent
Mississauga, ON L5K 1N9
Mbr: Al Schreiber

TECHNICAL

Herbert Lach
330 Banting Street
St. Bruno, PQ J3V 1Y3

MEDICAL

Dr. Peter Perry
64 Blair Road
Cambridge, ON N1S 2J1
Mbr: Dr. W. Delaney

TROPHIES & CLAIMS

Harold Eley
4136 Argyle Street
Regina, SK S4S 3L7

PUBLICITY

vacant

WORLD CONTEST

Al Schreiber
3298 Lone Feather Crescent
Mississauga ON L4Y 3G5
Mbrs: Hal Werneburg
Bruce Finlay

Coming Events

Jun 12-21, **1990 Canadian Nationals**, Starbuck.MB. Hosted by Winnipeg Gliding Club, contact Susan Snell for more information (204) 783-4983.

Jul 28-Aug 6, **Cowley Summer Camp and Senior XC Clinic**. Canada's biggest family fun soaring event. There is also a Senior XC Clinic, a first by the ASC (skill - Gold badge level recommended). If interested, please pre-register by letter to Hal Werneburg, 2940 Oakmoor Drive SW, Calgary, AB T2V 3Z4 (403) 238-1916.

Jul 28-Aug 6, **Flying Week at Beaver Valley Soaring**, 6 km W of Thornbury, Ontario on the south shore of Georgian